



INSTRUCTIONS 360 Y-DROP[®]

GENERAL INSTALL



INSTRUCTIONS

360 Y-DROP

GENERAL INSTALL

⊕ WARNING

- + These instructions are not specific to any Sprayer make or model. They are meant to be illustrative, part numbers and quantities shown herein may vary from your specific Sprayer Mount Package.

⊕ INTRODUCTION

- + Before beginning, it's important to know where each mounting bracket fits relative to the row spacing involved. The 360 Y-DROP unit should be precisely centered on the machine, as this is critical to the assembly of the system to the sprayer and for mounting the system to your sprayer boom. There are, however, many boom variations among all sprayer models. Your sprayer may not be identical to the model in the following steps of the guide, and the pictures may not exactly reflect your model. While these steps will help you install most of your 360 Y-DROP system, you may need to custom-fit some components with your particular boom.

⊕ RECOMMENDED TOOLS

- + Ratchet wrench with 1/2" and 9/16" deep well sockets
- + 3/8" 12-point socket
- + 1/2" and 9/16" combination wrenches
- + #2 Phillips screwdriver (for the shield installation)

⊕ TORQUE VALUES

- + Refer to these torque values when tightening all fasteners

+ 5/16" stainless	U-bolt	15 ft/lbs
+ 5/16" stainless	Set screw	15 ft/lbs
+ 3/8" carbon	U-bolt	35 ft/lbs
+ 5/16" carbon	U-bolt	30 ft/lbs
+ 5/16" carbon	Stop bolt	30 ft/lbs

⊕ NOTE

- + The Hardware Kit Labels and/or Bag Labels for your specific Sprayer Mount Package may differ from labels used in the following instructions.

⊕ QUESTIONS

- + Call our Product Support team at 888-512-4890

I. ESTABLISH DROP LOCATIONS

Figures 1 and 2

Step 1 Locate the center of the machine and identify the location of all the drops. On the sprayer boom, mark where each riser mount will be located. This will ensure that the extension tubes will not interfere with the riser mounts.

Figure 3

Step 2 For the primary boom, please refer to the 360 Y-DROP Extension Tube Mounting Guidelines.

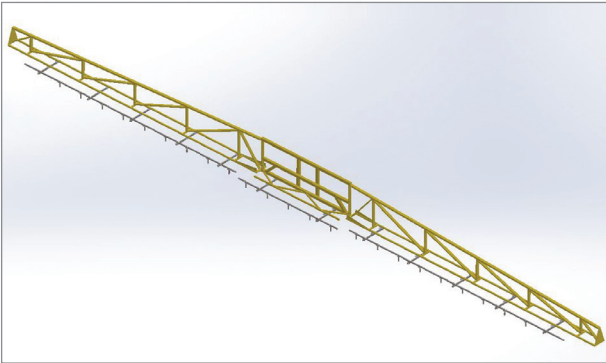

Figure 1

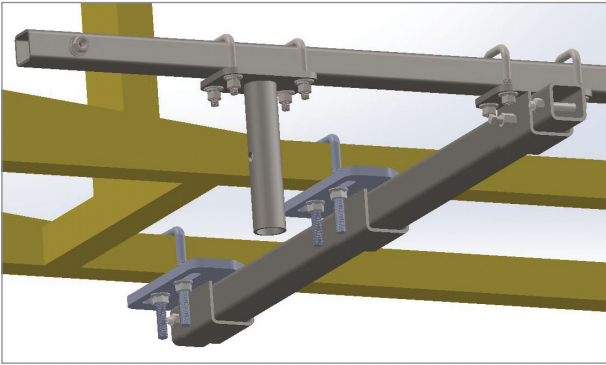

Figure 2

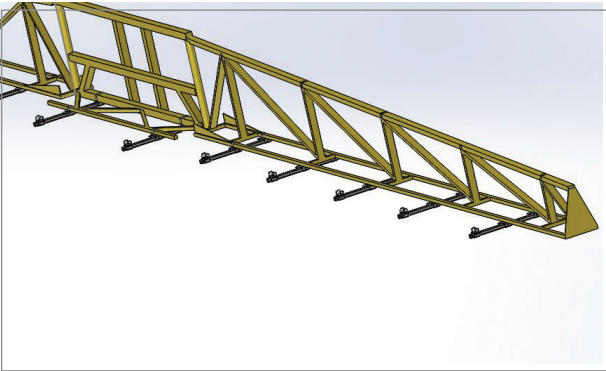

Figure 3

II. INSTALL MOUNT ASSEMBLIES ON THE OEM PRIMARY BOOM

NOTE: It is only on the 120' booms that the center section wet boom is below the OEM boom. On the 80', 90' and 100' booms, the wet boom is positioned higher. Keep this in mind, as the pictures that follow may not exactly match your equipment. This will not affect the installation of the 360 Y-DROP brackets.

Figure 4

Step 1 With the threads pointing down, install U-bolt (1) on the top of the OEM primary boom.

Step 2 Install bracket assembly (2) and flange lock nut (3).

Hardware Kit D

Repeat Steps 1 and 2 for the other OEM mount bracket kit.

Step 3 Install extension tube (4).

Step 4 Install boom bracket (5) onto the extension tube.

Step 5 Install square U-bolts (6), the 5/16" extra thick washers and the 5/16" nuts.

Hardware Kit A

Step 6 Install stop bolts (7) at both the front and the rear of the extension tube.

Hardware Kit B

Figure 5

Step 7 Install stainless steel set screw and jam nut assembly (1) onto the bracket assemblies.

Hardware Kit D

Repeat Steps 1-7 for the remaining mount assemblies on the OEM primary boom.

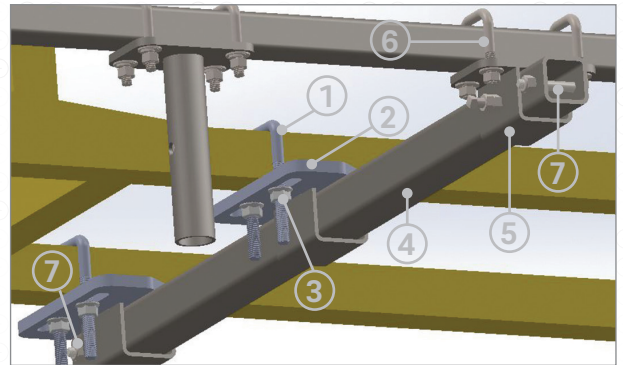

Figure 4

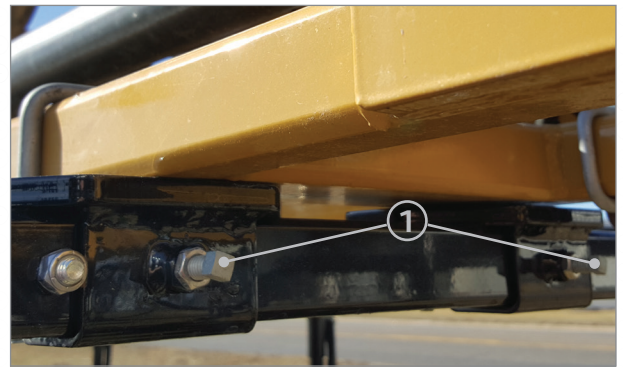

Figure 5

III. INSTALL CENTER SECTION SQUARE TUBE

Figure 6

Step 1 With the threads pointing down, install square U-bolt (1) on the front OEM center section boom.

Step 2 Position bracket assembly (2) and install 3/8" flange nuts (3).

Step 3 With the threads pointing down, install square U-bolt (4) on the rear OEM center section boom.

Step 4 Install adapter plate (5) and 3/8" flange nuts (6).

Step 5 Install extension tube (7) onto bracket assembly (2).

Figure 7

Step 6 Install boom bracket (1) onto extension tube (2).
Bag BB

Step 7 Install stop bolt assemblies (3).

Step 8 Install stop bolts (3) at both the front and the rear of the extension tube.

Repeat Steps 1-8 for the other center section mount.

Figure 8

Step 9 Install stainless steel set screw and jam nut assembly (1) onto the bracket assemblies.
Hardware Kit D

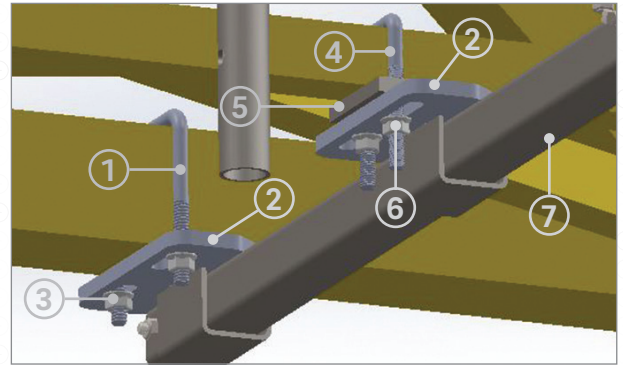

Figure 6

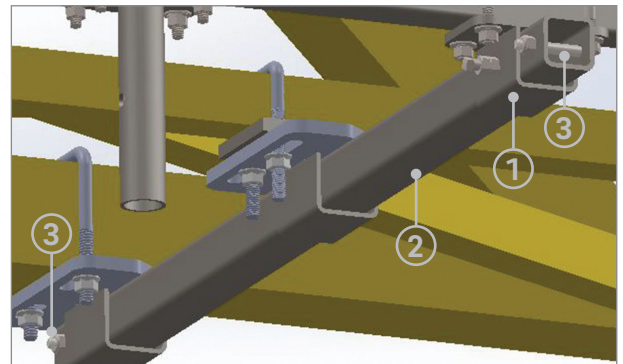

Figure 7



Figure 8

IV. INSTALL 360 Y-DROP BOOM

Figure 9

Step 1 Assemble 5' boom sections (1) using the 8" boom connectors (2) and the supplied hardware.

Hardware Bag CC

Step 2 Repeat Step 1 as needed in order to assemble the entire 360 Y-DROP boom.

Step 3 Set the 360 Y-DROP boom assembly onto boom bracket (3).

Repeat Steps 1 -3 for the remaining boom assemblies.



CAUTION: The 360 Y-DROP boom assembly may weigh up to 150 lbs. (68 kg). Exercise caution and enlist help for this process.

Figure 10

Step 4 In order to span the full length of the center section 360 Y-DROP boom, you will need to cut and drill one of the 5' boom sections to 1'. Mount this 1' section between two full 5' boom sections. Drill a 7/16" through hole centered 2" from the outside edge.

Figures 11 and 12

Step 5 Install square U-bolt (1), the 5/16" extra thick washers, and the 5/16" nuts over the 360 Y-DROP boom (2).

Hardware Kit A

Step 6 Install stop bolt (3) at both the front and the rear of the extension tube. Repeat for remaining stop bolts.

Hardware Kit B

Step 7 Install stainless steel set screw and jam nut assembly (4). See Figure 13 for detail. Repeat for the remaining mount assemblies on the primary boom.

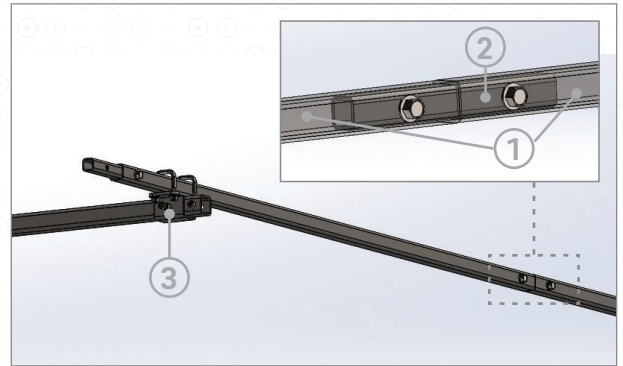

Figure 9



Figure 10

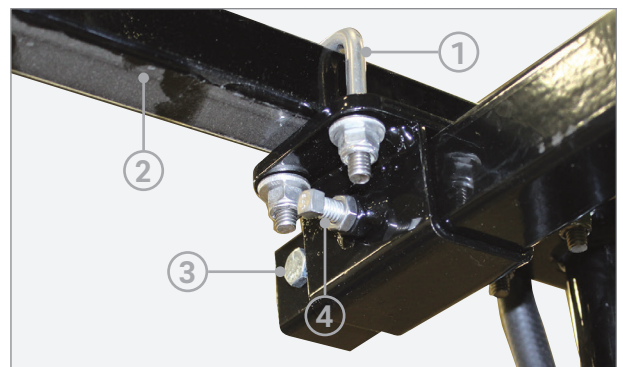

Figure 11

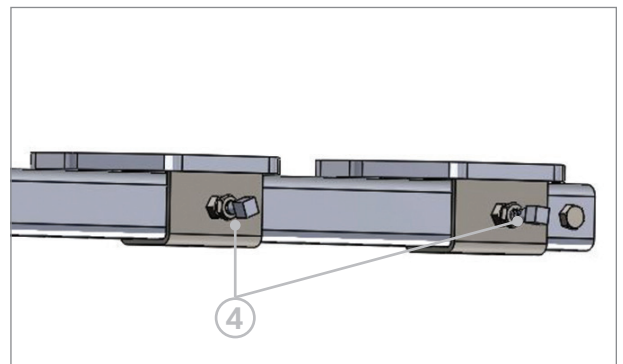

Figure 12

V.

INSTALL RISER MOUNTS

Figure 13

Step 1 Install riser mount (1) using the square U-bolts (2) and the extra thick washer and Nylock nut. Repeat for the remaining riser mounts.

Hardware Kit C

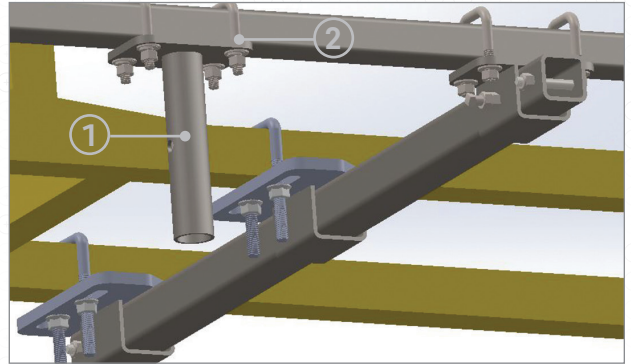

Figure 13

Figure 14

Figure 14 may show more or fewer riser mounts than your installation. The alignment and quantity of the riser mounts will depend on your row spacing.

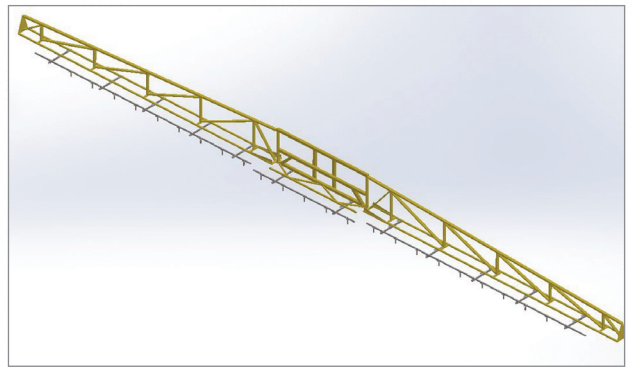

Figure 14

Figure 15

Step 2 Install riser tube assembly (1) into the riser mount (2).

Step 3 Install pin (3).

Repeat Steps 2 and 3 for the remaining riser tube assemblies.

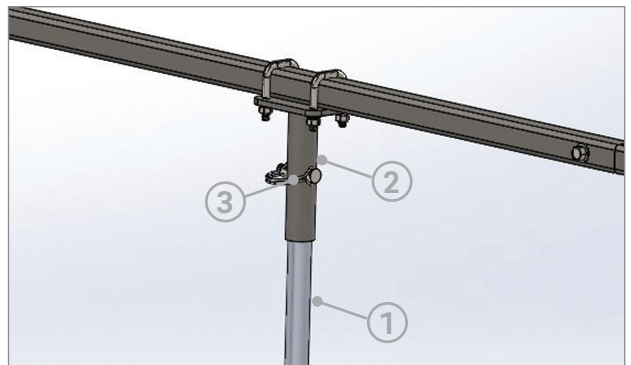

Figure 15

VI. INSTALL SHIELDS AND RISER HOSES

Figure 16

Step 1 Install shield (1) onto riser tube (2).

Figure 17

Step 2 Install base unit (1) onto riser tube (2).

Figure 18

Step 3 Assemble drag hoses (1) to 360 Y-DROP base and secure with hose clamps (2).

Figure 19

Step 4 Note the orientation of the drag hose clamps. The tails should point inward.

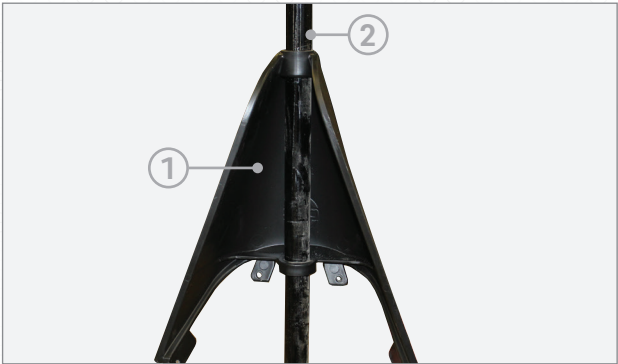

Figure 16

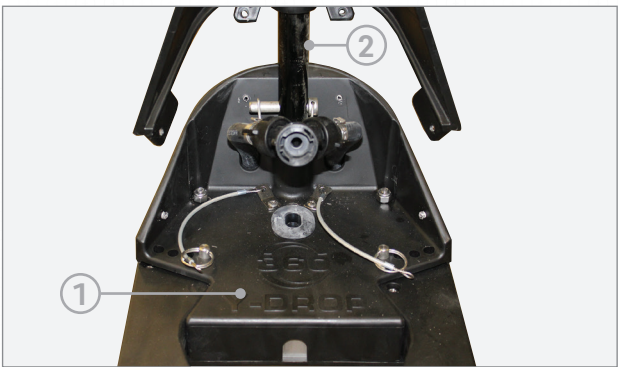

Figure 17

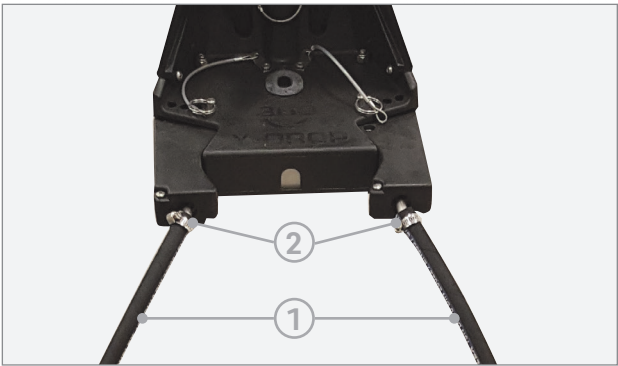

Figure 18



Figure 19

VI. INSTALL SHIELDS AND RISER HOSES *(continued)*

Figure 20



CAUTION: Do NOT use a drill or impact driver for Steps 5 and 6.

Step 5 Install two ½" screws (1).

Step 6 Install two ¾" screws (2).

Step 7 Install rubber washer (3) into the "Y".

Figure 21

Step 8 Install riser hose assembly (1) into the "Y".

Figure 22

Step 9 Route riser hose assembly (1) as shown in Figure 20.

Step 10 Install the riser hose assembly to the OEM nozzle body.

Step 11 Use 3 equally spaced plastic ties to secure the riser hose assembly.

Repeat Steps 1-11 for the remaining 360 Y-DROP Shields.

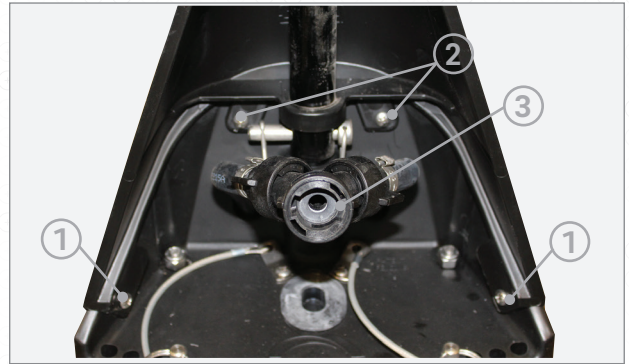

Figure 20

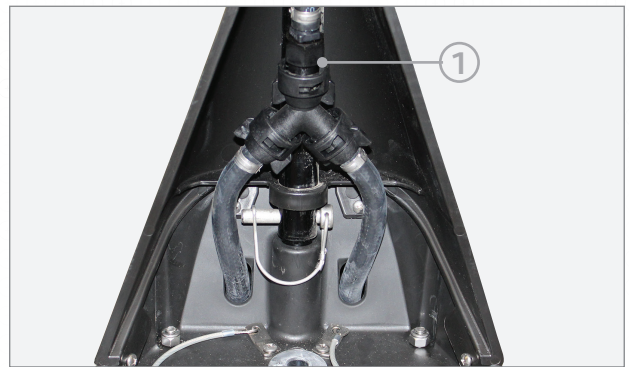

Figure 21



Figure 22

⊕ INSTALLATION COMPLETE.