



INSTRUCTIONS 360 Y-DROP[®]

CASE 120' BOOM



INSTRUCTIONS

360 Y-DROP

CASE 120' BOOM

⊕ INTRODUCTION

+ Before beginning, it's important to know where each mounting bracket fits relative to the row spacing involved. The 360 Y-DROP unit should be precisely centered on the machine, as this is critical to the assembly of the system to the sprayer and for mounting the system to your sprayer boom. There are, however, many boom variations among all sprayer models. Your sprayer may not be identical to the model in the following steps of the guide, and the pictures may not exactly reflect your model. While these steps will help you install most of your 360 Y-DROP system, you may need to custom-fit some components with your particular boom.

⊕ RECOMMENDED TOOLS

- + Ratchet wrench with 1/2" and 9/16" deep well sockets
- + 3/8" 12-point socket
- + 1/2" and 9/16" combination wrenches
- + #2 Phillips screwdriver (for the shield installation)

⊕ TORQUE VALUES

+ Refer to these torque values when tightening all fasteners

+ 5/16" stainless	U-bolt	15 ft/lbs
+ 5/16" stainless	Set screw	15 ft/lbs
+ 3/8" carbon	U-bolt	35 ft/lbs
+ 5/16" carbon	U-bolt	30 ft/lbs
+ 5/16" carbon	Stop bolt	30 ft/lbs

⊕ QUESTIONS

+ Call our Product Support team at 888-512-4890

I. ESTABLISH DROP LOCATIONS

Figures 1 and 2

Step 1 Locate the center of the machine and identify the location of all the drops. On the sprayer boom, mark where each riser mount will be located. This will ensure that the extension tubes will not interfere with the riser mounts.

Figure 3

Step 2 For the primary boom; starting at the wing fold pivot pin, measure out and make marks at 55", 115", 177", 217" and 257" (all measurements are ± 5 "). Repeat for the other primary boom.

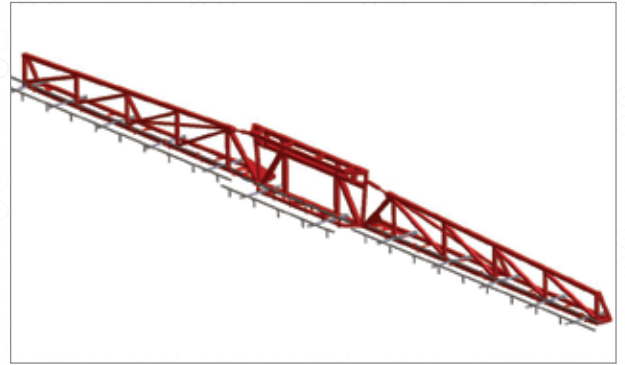

Figure 1



Figure 2

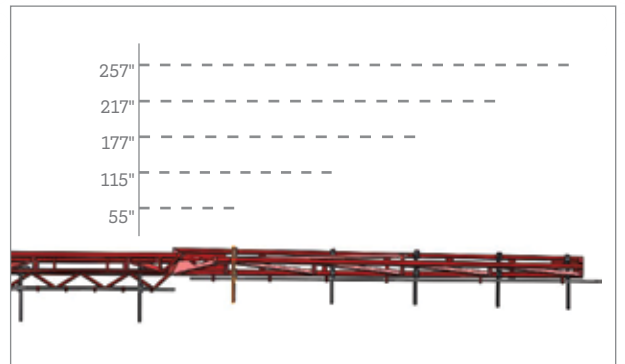

Figure 3

II. INSTALL MOUNT ASSEMBLIES ON THE OEM PRIMARY BOOM

Figure 4

Figure 4 shows size and location of U-bolts for OEM primary boom. The opposite arm of the central section will follow the same pattern as the arm shown.

Figure 5

Step 1 With the threads pointing up, install U-bolt (1) on the bottom side of the OEM primary boom.

Bag AA

Step 2 Install bracket assembly (2) and flange lock nut (3).

Hardware Kit D

Repeat Steps 1 and 2 for the other OEM mount bracket kit.

Step 3 Install extension tube (4).

Step 4 Install boom bracket (5) onto the extension tube.

Step 5 Install stop bolts (6) at both the front and the rear of the extension tube.

Hardware Kit B

Figure 6

Shows the positioning for the strap (1) and two 3/8" bolts and flange nuts (2) used for the OEM mount bracket on the outside mount of the primary boom.

Figure 7

Step 6 Install stainless steel set screw and jam nut assembly (7).

Hardware Kit D

Repeat Steps 1-6 for the remaining mount assemblies on the OEM primary boom.

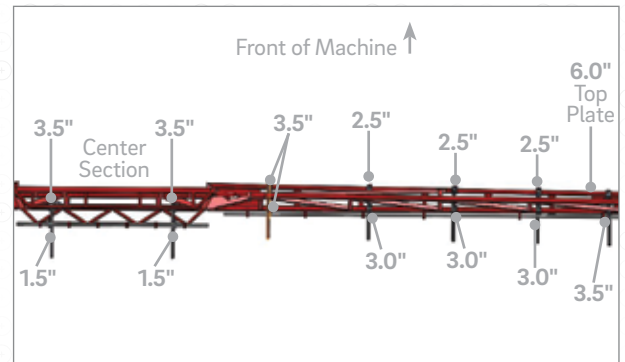

Figure 4

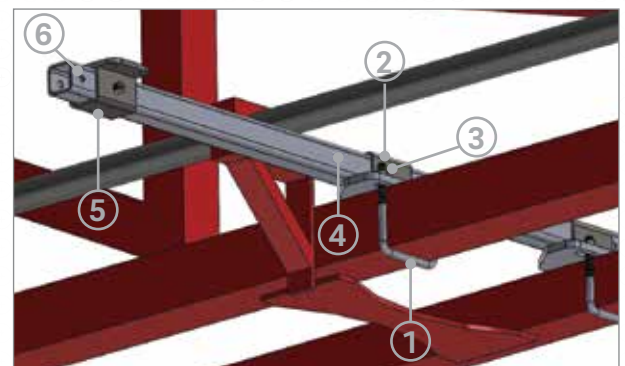

Figure 5

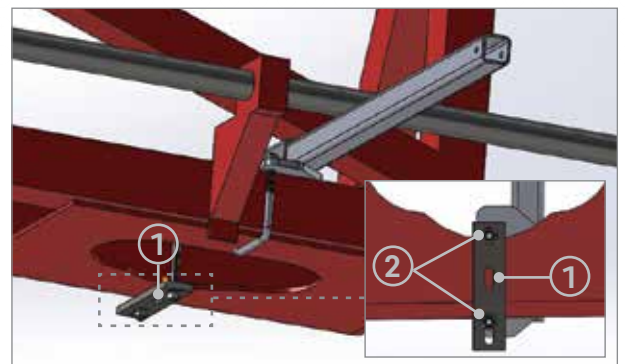

Figure 6

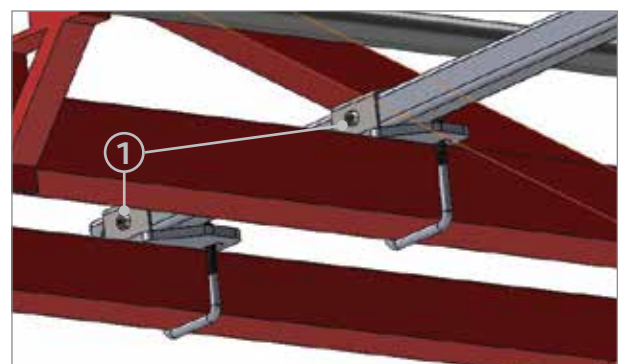

Figure 7

III. INSTALL CENTER SECTION SQUARE TUBE

Figure 8

Refer to Figure 4 for U-bolt locations.

Step 1 With the threads pointing up, install U-bolt (1) on the front OEM center section boom.

Bag AA

Step 2 Place bracket assembly (2) into position and install 3/8" flange nuts (3).

Repeat Steps 1 and 2 for the rear mount (4).

Step 3 Install extension tube (5) onto bracket assemblies (2) and (4).

Figure 9

Step 4 Install boom bracket (1) onto extension tube (2).

Step 5 Install stop bolts at both the front and the rear of the extension tube (3).

Hardware Kit B

Step 6 Install stainless steel set screw and jam nut assembly in boom bracket (4).

Repeat Steps 4-6 for left-hand mount on OEM center section.

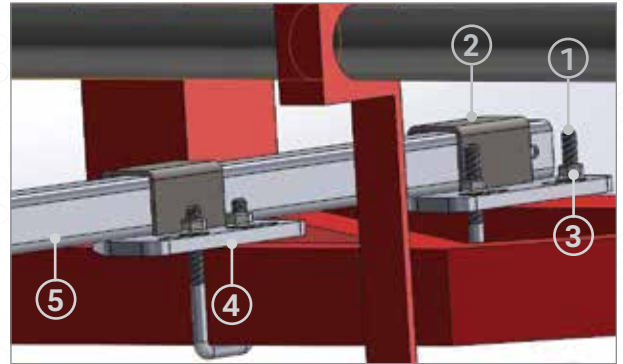

Figure 8

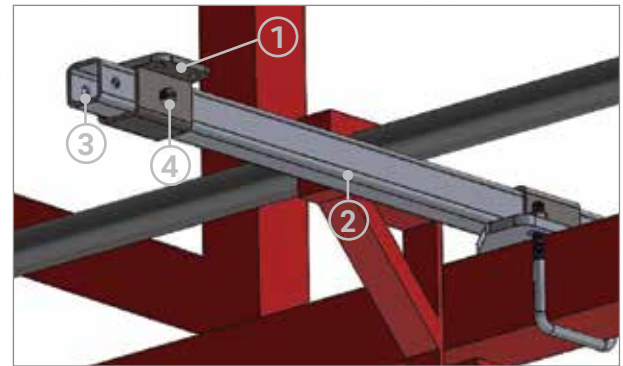

Figure 9

IV. INSTALL 360 Y-DROP BOOM

Figure 10

Step 1 Assemble 5' boom sections (1) using the 8" boom connectors (2) and the supplied hardware.

Hardware Bag CC

Step 2 Repeat Step 1 as needed in order to assemble the entire 360 Y-DROP boom.

Step 3 Set the 360 Y-DROP boom assembly onto boom bracket (3).

Repeat Steps 1 -3 for the remaining boom assemblies.



CAUTION: The 360 Y-DROP boom assembly may weigh up to 150 lbs. (68 kg). Exercise caution and enlist help for this process.

Figure 11

Step 4 In order to span the full length of the center section 360 Y-DROP boom, you will need to cut and drill one of the 5' boom sections to 1'. Mount this 1' section between two full 5' boom sections. Drill a 7/16" through hole centered 2" from the outside edge.

Figures 12 and 13

Step 5 Install square U-bolt (1), the 5/16" extra thick washers, and the 5/16" nuts over the 360 Y-DROP boom (2).

Hardware Kit A

Step 6 Install stop bolt (3) at both the front and the rear of the extension tube. Repeat for remaining stop bolts.

Hardware Kit B

Step 7 Install stainless steel set screw and jam nut assembly (4). See Figure 13 for detail. Repeat for the remaining mount assemblies on the primary boom.

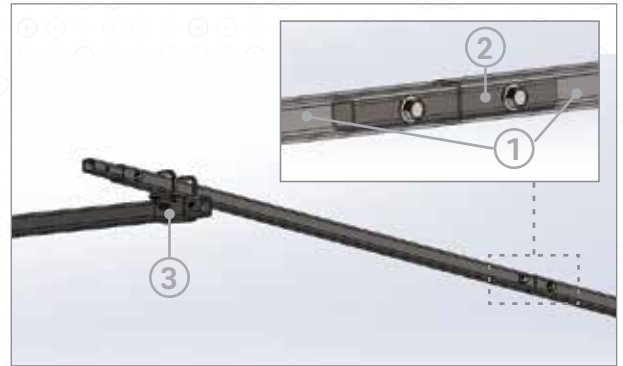

Figure 10



Figure 11

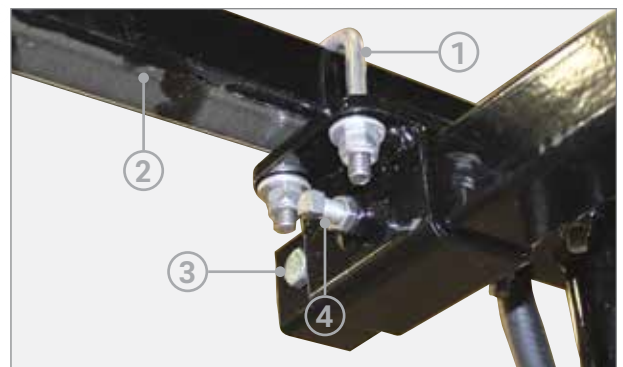

Figure 12

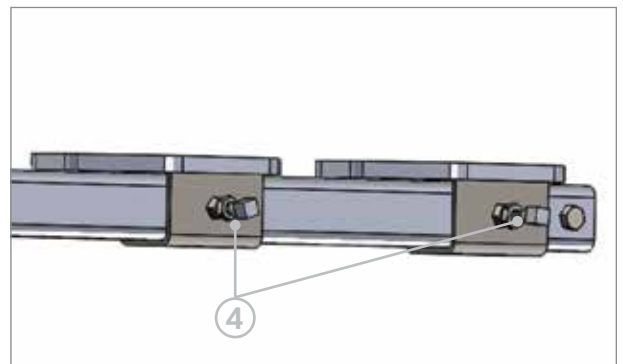

Figure 13

V.

INSTALL RISER MOUNTS

Figure 14

Step 1 Install riser mount (1) using the square U-bolts (2) and the extra thick washer and Nylock nut. Repeat for the remaining riser mounts.

Hardware Kit C

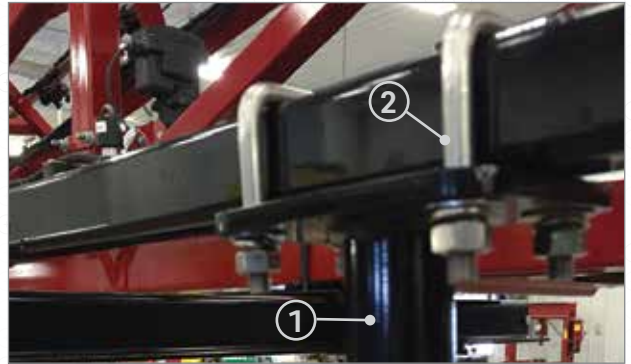

Figure 14

Figure 15

Figure 15 may show more or fewer riser mounts than your installation. The alignment and quantity of the riser mounts will depend on your row spacing.

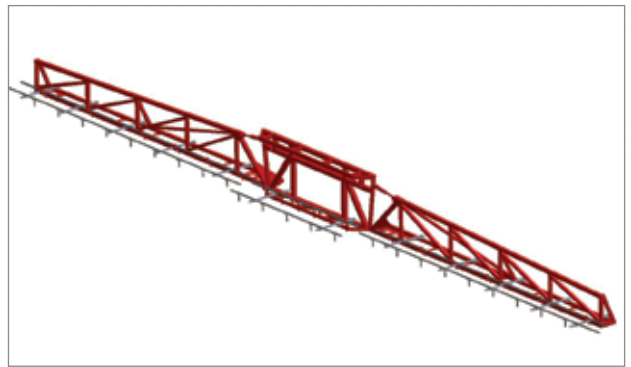

Figure 15

Figure 16

Step 2 Install riser tube assembly (1) into the riser mount (2).

Step 3 Install pin (3).

Repeat Steps 2 and 3 for the remaining riser tube assemblies.



Figure 16

VI. INSTALL SHIELDS AND RISER HOSES

Figure 17

Step 1 Install shield (1) onto riser tube (2).

Figure 18

Step 2 Install base unit (1) onto riser tube (2).

Figure 19

Step 3 Assemble drag hoses (1) to 360 Y-DROP base and secure with hose clamps (2).

Figure 20

Step 4 Note the orientation of the drag hose clamps. The tails should point inward.

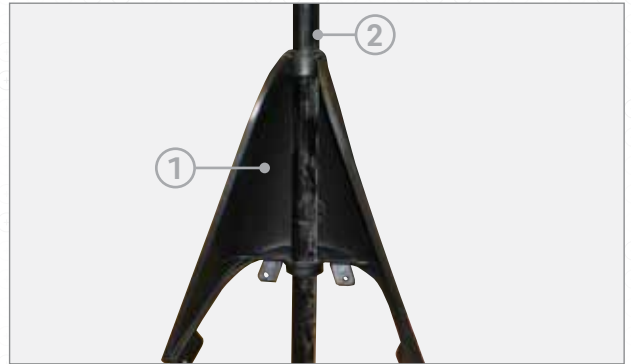

Figure 17



Figure 18

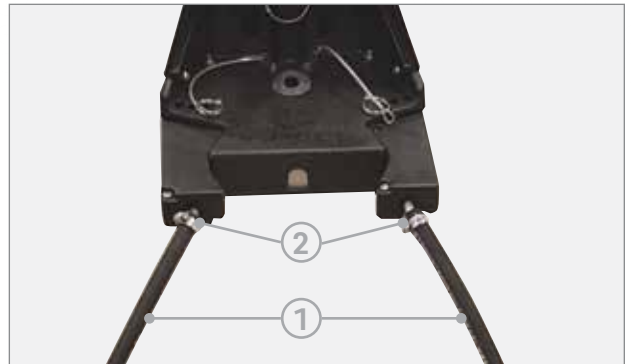

Figure 19



Figure 20

VI. INSTALL SHIELDS AND RISER HOSES *(continued)*

Figure 21



CAUTION: Do NOT use a drill or impact driver for Steps 5 and 6.

Step 5 Install two ½" screws (1).

Step 6 Install two ¾" screws (2).

Step 7 Install rubber washer (3) into the "Y".

Figure 22

Step 8 Install riser hose assembly (1) into the "Y".

Figure 23

Step 9 Route riser hose assembly (1) as shown in Figure 21.

Step 10 Install the riser hose assembly to the OEM nozzle body.

Step 11 Use 3 equally spaced plastic ties to secure the riser hose assembly.

Repeat Steps 1-11 for the remaining 360 Y-DROP Shields.

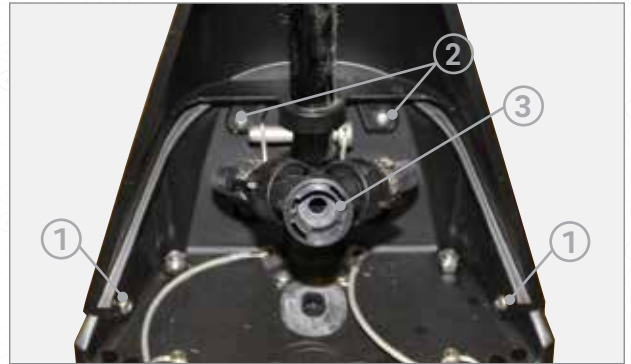

Figure 21

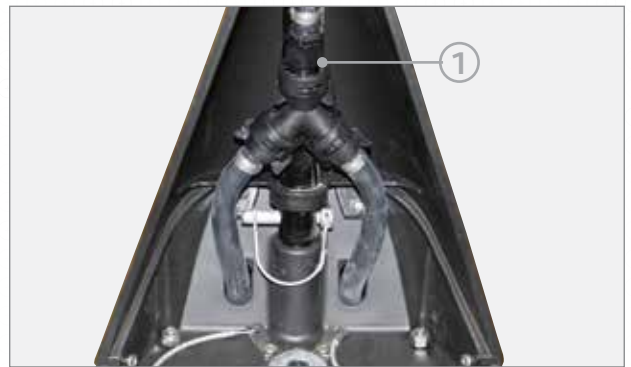

Figure 22



Figure 23

⊕ INSTALLATION COMPLETE.