

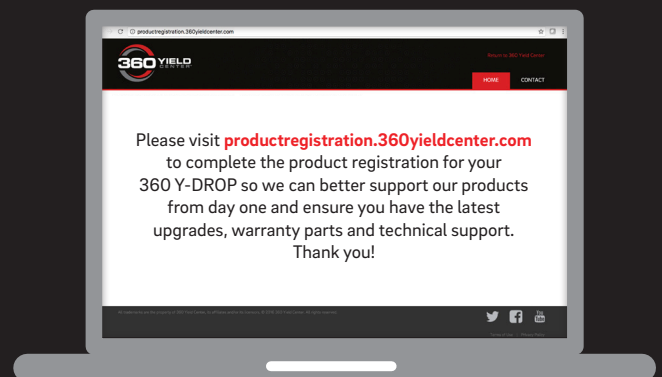

INSTRUCTIONS 360 Y-DROP®

HAGIE STS 80', 90' & 100' STEEL BOOMS

360 Y-DROP® REGISTRATION





INSTRUCTIONS 360 Y-DROP

HAGIE STS 80', 90' & 100' STEEL BOOMS

⊕ INTRODUCTION

+ Before beginning, it's important to know where each mounting bracket fits relative to the row spacing involved. The 360 Y-DROP unit should be precisely centered on the machine, as this is critical to the assembly of the system to the sprayer and for mounting the system to your sprayer boom. There are, however, many boom variations among all sprayer models. Your sprayer may not be identical to the model in the following steps of the guide, and the pictures may not exactly reflect your model. While these steps will help you install most of your 360 Y-DROP system, you may need to custom-fit some components with your particular boom.

⊕ RECOMMENDED TOOLS

- + Ratchet wrench with 1/2" and 9/16" deep well sockets
- + 3/8" 12-point socket
- + 1/2" and 9/16" combination wrenches
- + #2 Phillips screwdriver (for the shield installation)

⊕ TORQUE VALUES

+ Refer to these torque values when tightening all fasteners

+ 5/16" stainless	U-bolt	15 ft/lbs
+ 5/16" stainless	Set screw	15 ft/lbs
+ 3/8" carbon	U-bolt	35 ft/lbs
+ 5/16" carbon	U-bolt	30 ft/lbs
+ 5/16" carbon	Stop bolt	30 ft/lbs

⊕ QUESTIONS

- + Call our Product Support team at 888-512-4890

I. ESTABLISH DROP LOCATIONS

Figures 1 and 2

Step 1 Locate the center of the machine and identify the location of all the drops. On the sprayer boom, mark where each riser mount will be located. This will ensure that the extension tubes will not interfere with the riser mounts.

Figure 3

Step 2 From the center, measure out 51" ($\pm 5"$) on either side, as shown in Figure 3.

NOTE: The center mounting position will have to be offset in order to eliminate conflict with the center riser mount.

Step 3 For the primary boom; starting at the wing fold pivot pin, measure out and make marks at 50", 104", 168", 223" and 272" (all measurements are $\pm 5"$). Repeat for the other primary boom.

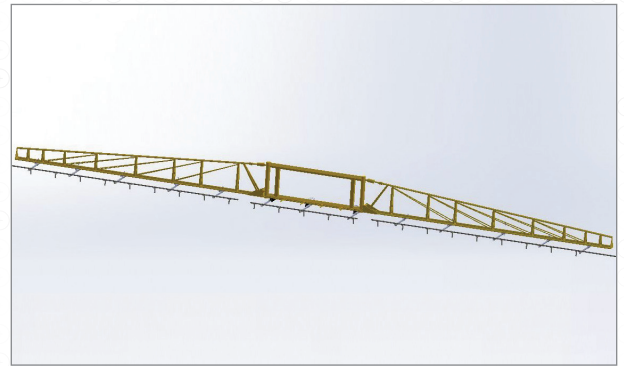

Figure 1

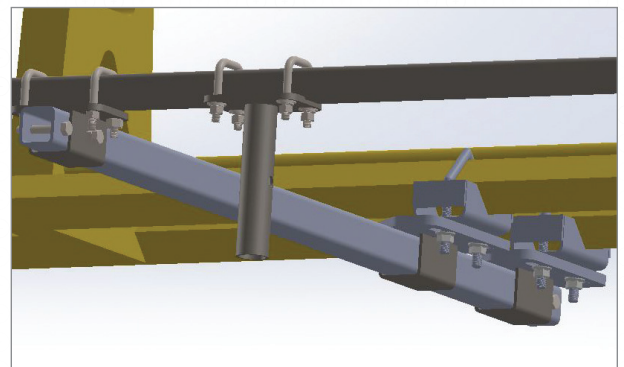

Figure 2

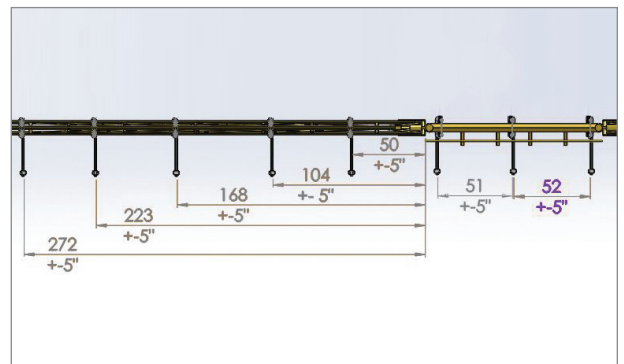

Figure 3

II.

INSTALL PRIMARY BOOM SPRAYER MOUNT PACKAGE

Figure 4

Step 1 With the threads pointing down, install diamond U-bolt (1) on the top side of the OEM primary boom.

Bag AC

Step 2 Install diamond boom clamp (2) on the bottom of the OEM primary boom.

Step 3 Install bracket assembly (3) and the flange lock nut (4).

Hardware Kit D

Step 4 Install extension tube (5).

Repeat Steps 1-4 for the the other OEM mount bracket.

Figure 5

Step 5 Install boom bracket (1) onto extension tube (2).

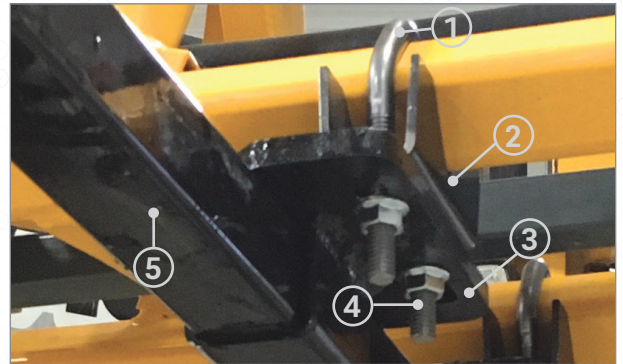

Figure 4

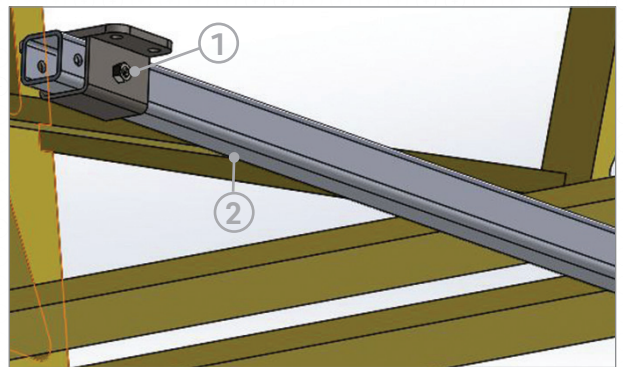

Figure 5

III. INSTALL CENTER SECTION EXTENSION TUBE

Figures 6 and 7

- Step 1** With the threads pointing down, install 4" diamond U-bolt (1) over the OEM center section boom.
- Step 2** Position diamond boom clamp (2), 14" top plate (3), bracket assembly (4) as shown in Figure 7, and install the 3/8" flange nuts (5).
- Step 3** Install extension tube (6) onto bracket assembly (4).
- Step 4** Install boom bracket (7).

Figure 8

- Step 5** Install a carriage bolt and nut (1) on the front and rear of the 14" top plate.
- Step 6** Install stainless steel set screw and jam nut assembly (2).

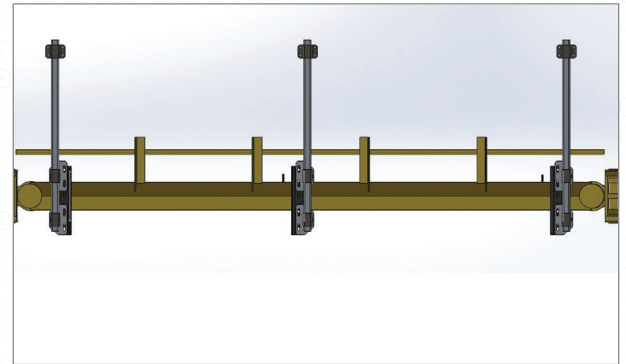

Figure 6

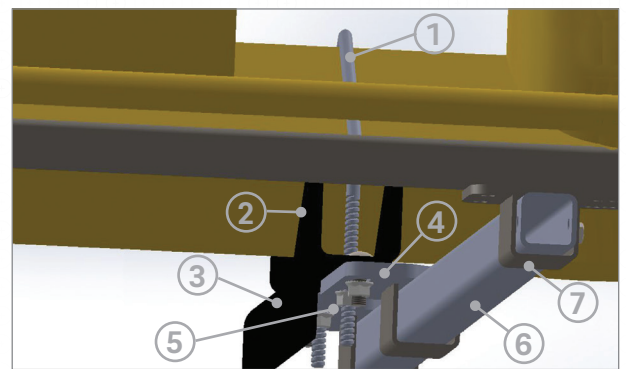

Figure 7

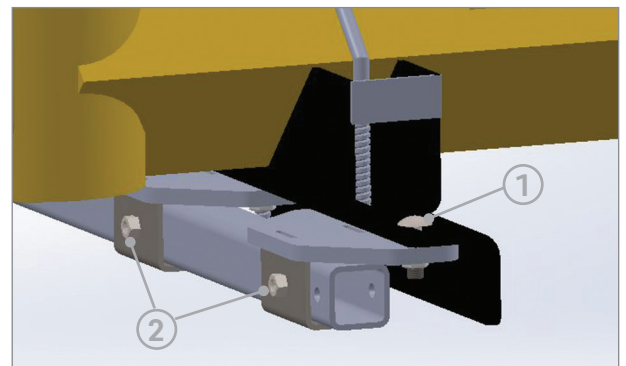

Figure 8

IV. INSTALL 360 Y-DROP BOOM

Figure 9

Step 1 Assemble 5' boom sections (1) utilizing 8" boom connectors (2) and the supplied hardware.

Hardware Bag CC

Step 2 Repeat Step 1 as needed in order to assemble the entire 360 Y-DROP boom.

Step 3 Set the 360 Y-DROP boom assembly onto boom bracket (3).

Repeat Steps 1-3 for the remaining boom assemblies.

CAUTION: The 360 Y-DROP boom assembly may weigh up to 150 lbs. (68 kg). Exercise caution and enlist help for this process.

Figure 10

Step 4 In order to span the full length of the center section 360 Y-DROP boom, you will need to cut and drill one of the 5' boom sections to 1'. Mount this 1' section between two full 5' boom sections. Drill a 7/16" through hole centered 2" from the outside edge.

Figures 11 and 12

Step 5 Install square U-bolt (1), the 5/16" extra thick washers, and the 5/16" nuts over the 360 Y-DROP boom (2).

Hardware Kit A

Step 6 Install stop bolt (3) at the both the front and the rear of the extension tube. Repeat for remaining stop bolts.

Hardware Kit B

Step 7 Install stainless steel set screw and jam nut assembly (4). See Figure 12 for detail. Repeat for the remaining mount assemblies on the primary boom.

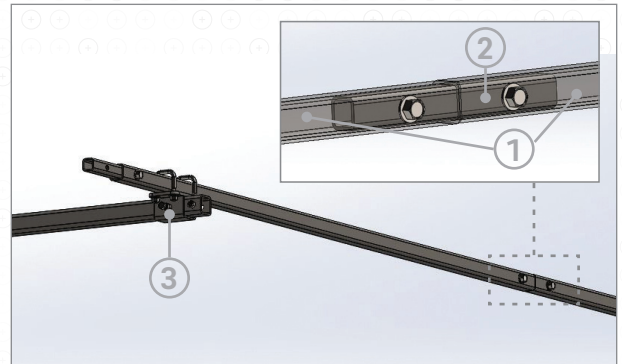

Figure 9



Figure 10

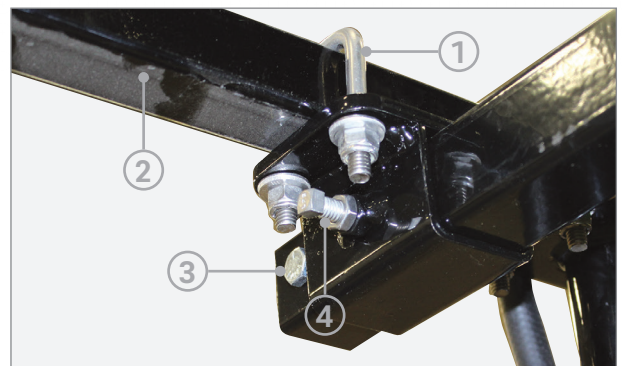

Figure 11



Figure 12

V.

INSTALL BREAKAWAY ASSEMBLY - ONE PIECE

Figure 13

Step 1 Install breakaway assembly - one piece (1) using the square U-bolts (2) and the extra thick washer and Nylock nut. Repeat for the remaining breakaway assemblies - one piece.

Hardware Kit C

Figure 14

Figure 14 may show more or fewer mounts than your installation. The alignment and quantity of the mounts will depend on your row spacing.

Figure 15

Step 2 Install riser tube assembly (1) into the breakaway assembly - one piece (2).

Step 3 Install pin (3).

Repeat Steps 2 and 3 for the remaining riser tube assemblies.

NOTE: Included in most sprayer mount packages are standard riser mounts to be used when primary booms are folded and in transport mode. These standard riser mounts should be mounted in locations that allow you to relocate the drops away from potential tire interference. See "Install Riser Mounts Without Breakaway Assemblies" section on next page for more instructions.

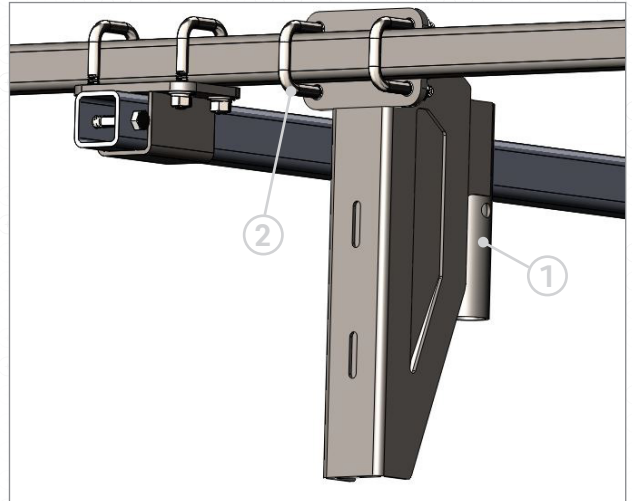

Figure 13

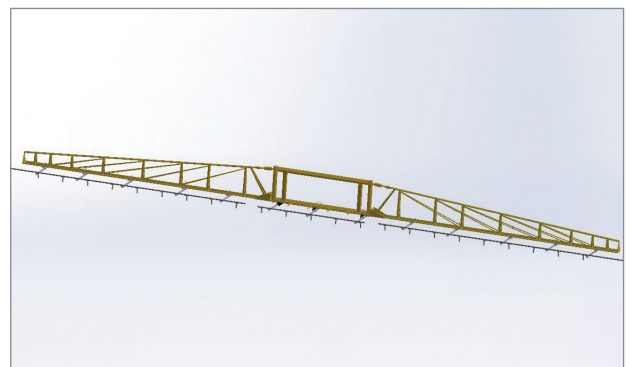

Figure 14

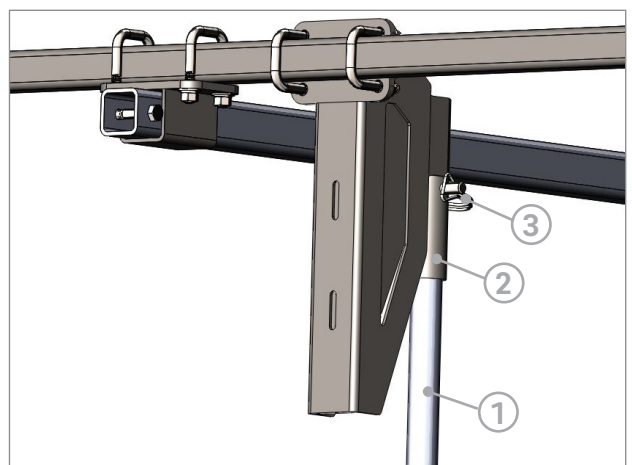

Figure 15

V.

INSTALL RISER MOUNTS WITHOUT BREAKAWAY ASSEMBLIES (OPTIONAL)

Figure 16

Step 1 Install riser mount (1) using the square U-bolts (2) and the extra thick washer and nylock nut. Repeat for the remaining riser mounts.

Hardware Kit C

Figure 17

Figure 17 may show more or fewer riser mounts than your installation. The alignment and quantity of the riser mounts will depend on your row spacing.

Figure 18

Step 2 Install riser tube assembly (1) into the riser mount (2).

Step 3 Install pin (3).

Repeat Steps 2 and 3 for the remaining riser tube assemblies.

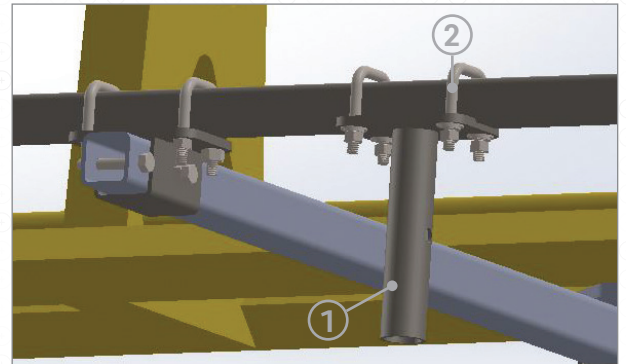

Figure 16

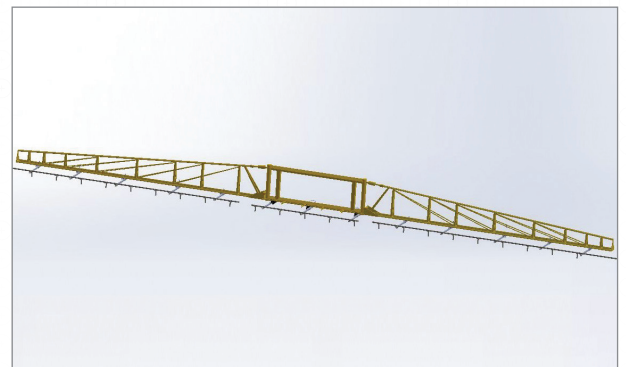

Figure 17

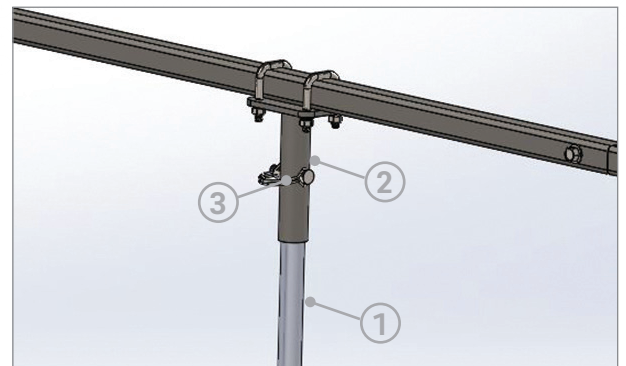

Figure 18

VI. INSTALL SHIELDS AND RISER HOSES

Figure 19

Step 1 Install shield (1) onto riser tube (2).

Figure 20

Step 2 Install base unit (1) onto riser tube (2).

Figure 21

Step 3 Assemble drag hoses (1) to 360 Y-DROP base and secure with hose clamps (2).

Figure 22

Step 4 Note the orientation of the drag hose clamps. The tails should point inward.

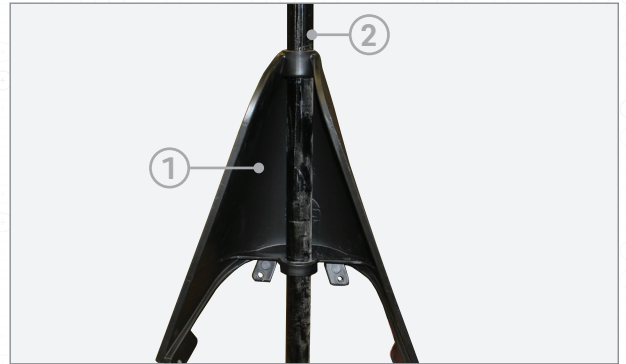

Figure 19

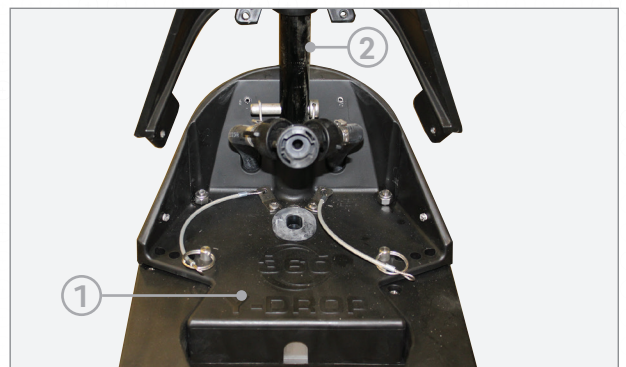

Figure 20

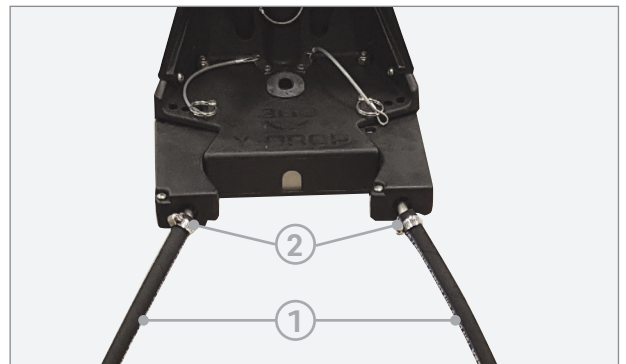

Figure 21



Figure 22

VI. INSTALL SHIELDS AND RISER HOSES (CONTINUED)

Figure 23



CAUTION: Do NOT use a drill or impact driver for Steps 5 and 6.

Step 5 Install two ½" screws (1).

Step 6 Install two ¾" screws (2).

Figure 24

Step 7 Install rubber washer (3) into the "Y".

Figure 25

Step 8 Install riser hose assembly (1) into the "Y".

Figure 26

Step 9 Route riser hose assembly (1) as shown in Figure 23.

Step 10 Install the riser hose assembly to the OEM nozzle body.

Step 11 Use 3 equally spaced plastic ties to secure the riser hose assembly.

Repeat Steps 1-11 for the remaining shield assemblies.

⊕ INSTALLATION COMPLETE.

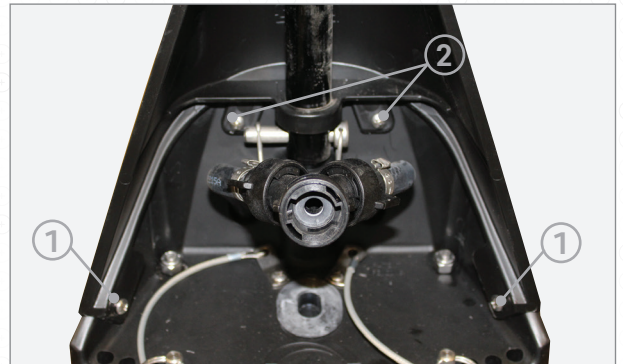

Figure 23

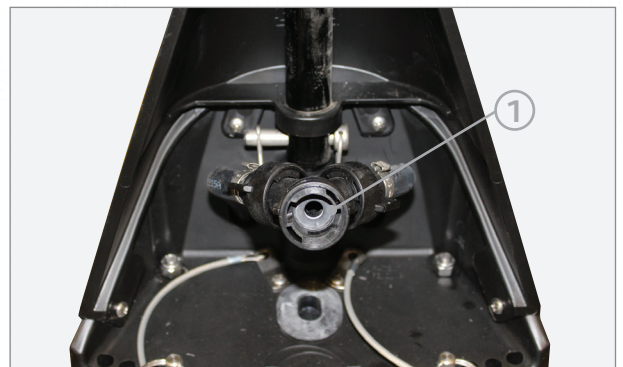

Figure 24



Figure 25



Figure 26