

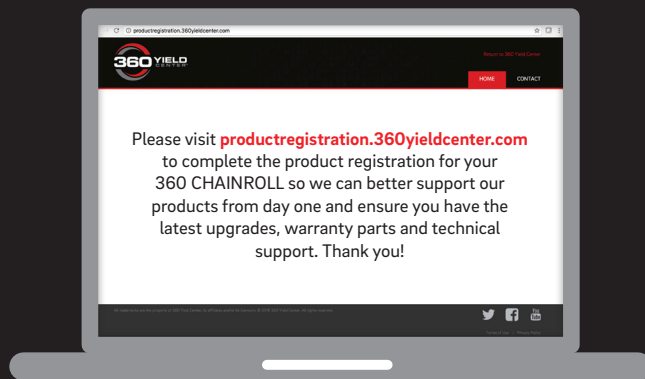

# INSTRUCTIONS 360 CHAINROLL™

JOHN DEERE 40/90 SERIES

## 360 CHAINROLL™ REGISTRATION



[360YIELDCENTER.COM](http://360YIELDCENTER.COM)

V4 - 08.18.2017

# INSTRUCTIONS

## 360 CHAINROLL

JOHN DEERE 40/90 SERIES

### PARTS OVERVIEW

#### 360 CHAINROLL ROW UNIT KIT - JD 40/90 SERIES (PART NO. 451300)

- + Left 360 CHAINROLL (Part No. 450301)
- + Right 360 CHAINROLL (Part No. 450311)
- + (4) 1/2" Roll Pins (Part No. 207032)
- + (4) 5/16" Roll Pins (Part No. 207033)
- + (4) M10 Socket Head Cap Screws (Part No. 207034)

#### 360 CHAINROLL RESIDUE KNIVES (PART NO. 450230)

- + 360 CHAINROLL Residue Knife Left (Part No. 450340)
- + 360 CHAINROLL Residue Knife Right (Part No. 450350)

### ROLL ORIENTATION

**IMPORTANT:** Left ("L") and Right ("R") are defined from the perspective of the operator's seat. Make sure the rolls are properly aligned and intermeshed when installing them onto the drive shafts by aligning the yellow timing marks as shown in the figure below. Once installed, if the rolls are making contact with each other, remove rolls and rotate the shafts 180 degrees and reinstall the rolls. If the rolls continue to make contact with each other after rotating the shafts a full 360 degrees, contact your John Deere dealer to have the shaft alignment inspected.

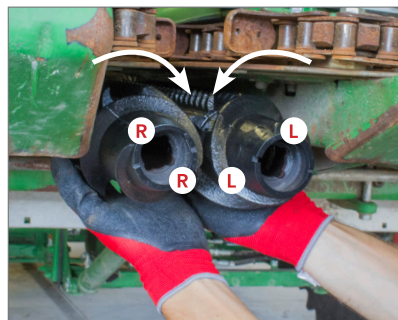
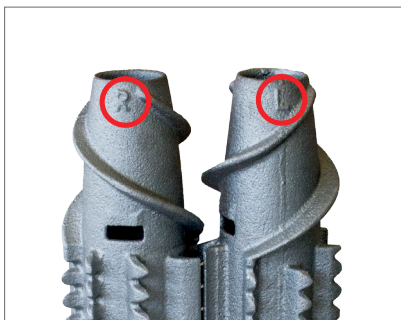

### QUESTIONS

Call our Product Support Team at **888-512-4890**.

I.

## FLUTED (90 SERIES) / TAPERED (40 SERIES) STALK ROLL REMOVAL

### JOHN DEERE 40/90 SERIES

#### PART 1: REMOVE RESIDUE KNIVES

##### TOOLS AND PARTS REQUIRED:

- + 18mm Socket (90 Series)
- + 3/4" (19mm) Socket (40 Series)

FIGURE 1

**STEP 1** Remove the four M12 flange head cap screws.

**STEP 2** Repeat Step 1 for the adjacent roll.

#### PART 2: REMOVE CAP SCREWS AND ROLL PINS

##### TOOLS AND PARTS REQUIRED:

- + 18mm Socket (90 Series)
- + 3/4" (19mm) Socket (40 Series)
- + Hammer / 1/2" Straight Punch
- + Air Hammer / 1/2" Punch Bit Recommended

FIGURE 2

**STEP 1** Rotate the stalk roll to access one of the two clamping cap screws (located near the middle of roll).

**STEP 2** Use an impact wrench and 18mm socket (90 Series) or 3/4" socket (40 Series) to remove the cap screws.

FIGURE 3

**STEP 3** Rotate the stalk roll to access the roll pins (located at the front of the casting).

**STEP 4** Using an air hammer and 1/2" punch bit (or hammer and punch), drive the roll pins out of the casting.

**STEP 5** Repeat Steps 1-4 for the adjacent roll.



FIGURE 1



FIGURE 2



FIGURE 3

I.

## FLUTED (90 SERIES) / TAPERED (40 SERIES) STALK ROLL REMOVAL

### JOHN DEERE 40/90 SERIES

#### PART 3: REMOVE OEM STALK ROLLS

##### TOOLS AND PARTS REQUIRED:

- + 360 CHAINROLL Puller or Equivalent
- + 1-1/2" Socket

**STEP 1** Rotate stalk rolls until pulling features are facing towards stripper plate gap. Improve accessibility by opening up stripper plates, if needed.

FIGURE 4

**STEP 2** Ensure that T-handle is fully retracted, then attach puller arms to pulling features on the rolls, as shown. **Reference Puller Insert, Page 9.**

**STEP 3** Apply initial tension on puller by tightening the 1-1/2" hex feature (puller body).

FIGURE 4

**STEP 4** Extend hydraulic puller by turning T-handle, as shown, to break stalk roll free.

**NOTE:** If necessary use the striking lug for added force after ram is fully extended.

FIGURE 5

**STEP 5** If needed, remove the T-handle and apply torque to the body of the puller utilizing the 1-1/2" socket.

If puller force is required to completely remove the roll, install the longer ram insert and utilize the 1-1/2" socket to completely remove the roll.

**STEP 6** Repeat Steps 1-4 for the adjacent roll.



FIGURE 4



FIGURE 5

II.

## KNIFE ROLLS (3 PIECE) STALK ROLL REMOVAL

### JOHN DEERE 40/90 SERIES

#### PART 1: REMOVE RESIDUE KNIVES

##### TOOLS AND PARTS REQUIRED:

+ 18mm Socket

FIGURE 6

**STEP 1** Remove the four M12 flange head cap screws.

**NOTE:** Retain screws for installation of new residue knives.

**STEP 2** Repeat Step 1 for the adjacent roll.

#### PART 2: REMOVE REAR STALK ROLL BOLTS

##### TOOLS AND PARTS REQUIRED:

+ 13mm (1/2") Socket

+ Socket Extension

FIGURE 7

**STEP 1** Rotate the stalk roll to access one of the rear cap screws.

**STEP 2** Remove cap screws using extension.

**STEP 3** Rotate the stalk roll to access and remove the second rear cap screws.

**STEP 4** Repeat steps 1-3 for the opposite side.

#### PART 3: REMOVE STALK ROLL HALVES

##### TOOLS AND PARTS REQUIRED:

+ 16mm (5/8") Socket

FIGURE 8

**STEP 1** Rotate the stalk rolls to access the four cap screws on one half of the roll.

**STEP 2** Remove all four cap screws and stalk roll half.

FIGURE 8

**STEP 3** Rotate the stalk roll to access the other stalk roll half and cap screws.

**STEP 4** Remove all four cap screws and stalk roll half.

**STEP 5** Repeat Steps 1-4 for the adjacent roll.



FIGURE 6



FIGURE 7



FIGURE 8

II.

## KNIFE ROLLS (3 PIECE) STALK ROLL REMOVAL

### JOHN DEERE 40/90 SERIES

#### PART 4: REMOVE MACHINE SCREWS AND ROLL PINS

##### TOOLS AND PARTS REQUIRED:

- + T45 Torx Bit
- + Hammer / 1/2" Straight Punch
- + Air Hammer / 1/2" Punch Bit Recommended

FIGURE 9

**STEP 1** Rotate stalk roll to access the T45 machine screws.

**STEP 2** Using the T45 torx bit, remove the two screws.

**STEP 3** Rotate the stalk roll to access the roll pins (located at the front of the casting).

**STEP 4** Repeat Steps 1-4 for the adjacent roll.

#### PART 5: REMOVE OEM STALK ROLLS

##### TOOLS AND PARTS REQUIRED:

- + 360 CHAINROLL Puller or Equivalent
- + 1-1/2" Socket

**STEP 1** Rotate stalk rolls until pulling features are facing towards stripper plate gap. Improve accessibility by opening up stripper plates, if needed.

FIGURE 10

**STEP 2** Ensure that T-handle is fully retracted, then attach puller arms to pulling features on the rolls, as shown. **Reference Puller Insert, Page 9.**

**STEP 3** Apply initial tension on puller by tightening the 1-1/2" hex feature (puller body).

FIGURE 10

**STEP 4** Extend hydraulic puller by turning T-handle, as shown, to break stalk roll free.

**NOTE:** If necessary use the striking lug for added force after ram is fully extended.

FIGURE 11

**STEP 5** If needed, remove the T-handle and apply torque to the body of the puller utilizing the 1-1/2" socket.

If puller force is required to completely remove the roll, install the longer ram insert and utilize the 1-1/2" socket to completely remove the roll.

**STEP 6** Repeat Steps 1-4 for the adjacent roll.



FIGURE 9



FIGURE 10



FIGURE 11



## 360 CHAINROLL INSTALLATION

### JOHN DEERE 40/90 SERIES

#### PART 1: INSTALL 360 CHAINROLL

##### TOOLS AND PARTS REQUIRED:

- + Anti-Seize (Not Included)
- + Emery Cloth (Not Included)
- + Left 360 CHAINROLL
- + Right 360 CHAINROLL
- + 1/2" Roll Pins / Punch
- + 5/16" Roll Pins / Punch
- + Air Hammer Recommended and 360 Punch Bits

FIGURE 12

**STEP 1** Rotate the drive shafts so the roll pin holes face upwards diagonally from right to left as you look at the row unit, as shown.

**STEP 2** Apply anti-seize around the outer surface of the first and third sections of the steel shafts.

FIGURE 13

**STEP 3** Position 360 CHAINROLL such that the opposed facing flutes [cutting and retaining] are contained within the adjacent facing flutes [cutting and chaining].

**Reference cutaway in Figure 13.**

**STEP 4** Slide the stalk rolls simultaneously onto the drive shafts making sure the roll pin holes on the drive shafts align with roll pin holes on stalk rolls.

**NOTE:** 40 Series shafts only have 1 roll pin hole. Install roll pin in forward most roll pin hole on 360 CHAINROLL.

**STEP 5** Insert one of the 1/2" roll pins into the pin hole and tap in until it won't fall out. In the hole that is open, insert a long punch or straight tool (approximately 1/2" dia.) through the hole to ensure the roll pin holes on the shaft stay aligned with the stalk roll.

FIGURE 14

**STEP 6** Using an air hammer (or hammer and 1/2" punch bit), drive the first roll pin in until it is inset slightly on both sides of the stalk roll.

**STEP 7** Insert one of the 5/16" roll pins into the 1/2" roll pin already in the stalk roll and tap in slightly until it doesn't fall out.

FIGURE 15

**STEP 8** Using an air hammer and 5/16" punch bit (or hammer and punch), drive the 5/16" roll pin through 1/2" pin until it is inset slightly on both sides.



FIGURE 12

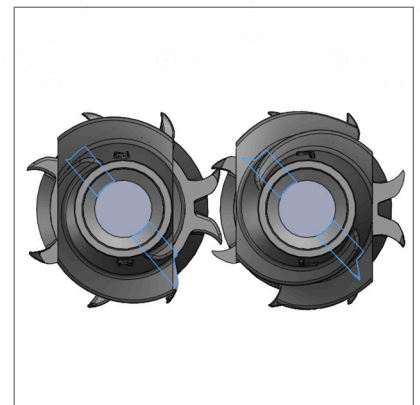

FIGURE 13



FIGURE 14



FIGURE 15

III.

## 360 CHAINROLL INSTALLATION

### JOHN DEERE 40/90 SERIES

**STEP 9** Repeat steps 5-8 for roll pin on the opposite roll.

**STEP 10** Manually turn stalk rolls a full revolution to ensure no interferences exist.

**STEP 11** Repeat Steps 5-8 for any remaining roll pin holes.

### PART 2: CLAMP THE 360 CHAINROLL

#### TOOLS AND PARTS REQUIRED:

- + M10 Socket Head Cap Screw
- + M8 Hex Drive
- + Torque Wrench

FIGURE 16 & 17

**STEP 1** Rotate the stalk rolls to access the bolt holes near the center of the stalk roll.

**STEP 2** Follow this bolt torquing sequence for each roll:  
Torque first bolt to final torque of 70 ft-lbs (95 Nm).  
Torque second bolt to final torque of 70 ft-lbs (95 Nm).  
Retorque first bolt to final torque of 70 ft-lbs (95 Nm).  
Retorque second bolt to final torque of 70 ft-lbs (95 Nm).

**STEP 3** Repeat Steps 1-2 for the other stalk roll.

**NOTE:** If grower removes or gets new bolts it is recommended to lubricate with a multi-purpose lubricant (such as WD 40) before reinstalling

**NOTE:** It is recommended to check bolt torque after approximately 8 hours of operation due to potential loosening of bolts from head vibration.

### PART 3: REINSTALL RESIDUE KNIVES

#### TOOLS AND PARTS REQUIRED:

- + 18mm Socket

FIGURE 18

**STEP 1** Install new 360 CHAINROLL Residue Knives or reworked OEM knives using the four M12 flange head cap screws. Start from the rear and do not fully tighten.

**NOTE:** Call your 360 Yield Center Dealer or 360 Yield Center Product Support Team for the Residue Knife Template.

**STEP 2** Adjust spacing of the residue knife to approximately 1/4" clearance from the 360 CHAINROLL knife edge. Tighten the first and third bolts.

**STEP 3** Tighten the remaining bolts.

**STEP 4** Repeat Steps 1 - 3 for the opposite side.

**+** INSTALLATION COMPLETE



FIGURE 16



FIGURE 17



FIGURE 18



**PULLER INSERT**  
JOHN DEERE 40/90 SERIES

