



# 360 CHAINROLL®

INSTALLATION INSTRUCTIONS  
GERINGHOFF NORTHSTAR



[360YIELDCENTER.COM](http://360YIELDCENTER.COM)

FOR QUESTIONS PLEASE CONTACT OUR  
PRODUCT SUPPORT TEAM AT 309-300-3120

8.13.19 • V10



# INSTALLATION INSTRUCTIONS

GERINGHOFF NORTHSTAR



## CROSS AUGER SIDE

R1

R2

R3

R4

L1

L2

L3

L4



## HARDWARE

## FRONT OF SNOOT

# INSTALLATION INSTRUCTIONS

GERINGHOFF NORTHSTAR • THREADED SHAFT



## BEFORE YOU BEGIN



The following instructions are for Geringhoff rows with a **threaded shaft**. For installation instructions for rows with a **non-threaded (through) shaft** please refer to pages 5-7.

### HELPFUL TOOLS

- 10 mm hex shaft driver
- 16 mm and 17 mm sockets

### NEED HELP?

Call our Product Support team at 309-300-3120.

## STEP 1

### OEM ROLL DISASSEMBLY

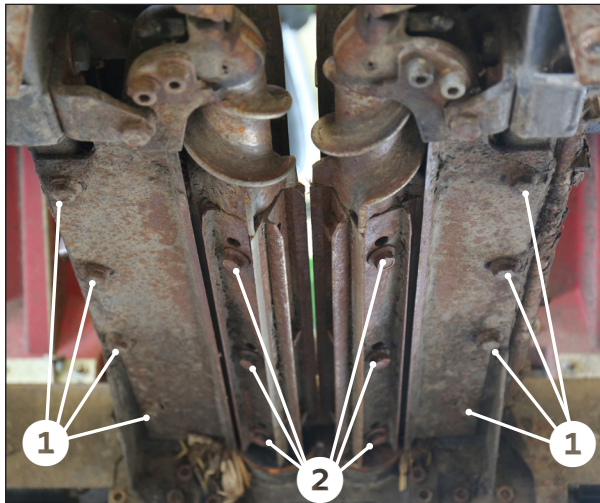

We have found the best way to install 360 CHAINROLL is by removing the residue knives and replacing the OEM roll knives with 360 CHAINROLL from the bottom side of the head.

On each row where 360 CHAINROLL will be installed, remove the four bolts **1** on each OEM residue knife. Retain these bolts for use when installing the 360 Residue Knives later in the installation process.

Remove the three bolts **2** in each OEM plate to uninstall all OEM plates on each row where 360 CHAINROLL will be installed. To gain access to all four sides of each shaft, the rolls may need to be rotated multiple times. This hardware can be discarded.

## BEFORE YOU BEGIN ASSEMBLY

### PLEASE NOTE

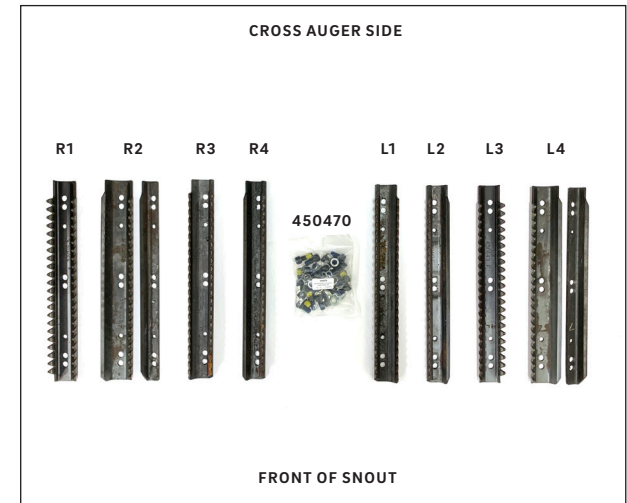

We recommend opening **only one row at a time**. Layout one bundled left kit and one bundled right kit under each row, keeping in mind that **left and right are determined from the operator's seat**.

Arrange the knives as shown in the picture above:  
R1 - R2 (consists of two pieces) - R3 - R4  
L1 - L2 - L3 - L4 (consists of two pieces)

**NOTE: The stamped numbers indicated the back of the knife which should be oriented towards the cross auger side of the head.**

For assembly on threaded shafts, only use the hardware from **hardware kit 450470**. Hardware in kit 450471 will not be used for this type of shaft.



# INSTALLATION INSTRUCTIONS

GERINGHOFF NORTHSTAR • THREADED SHAFT



## STEP 2 INSTALL R1 AND L1

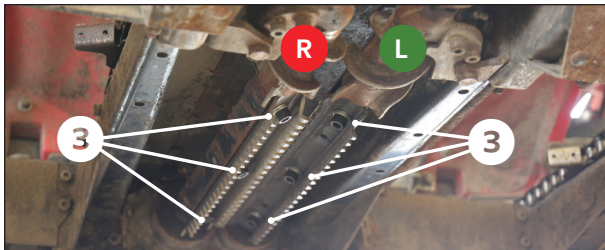
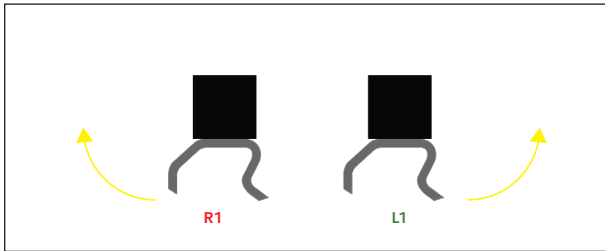

Using three of the shorter M12 bolts and lock washers from **hardware kit 450470 ③**, install the **R1** plate on the **right roll**.

Using three of the shorter M12 bolts and lock washers from **hardware kit 450470 ③**, install the **L1** plate on the **left roll**.

Torque all three bolts on both the left and the right rolls to 100ft/lbs.

Rotate the head as it would in normal operation to access the next face of the shaft.

## STEP 3 INSTALL R2 AND L2

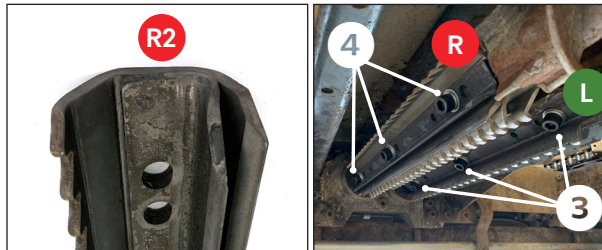
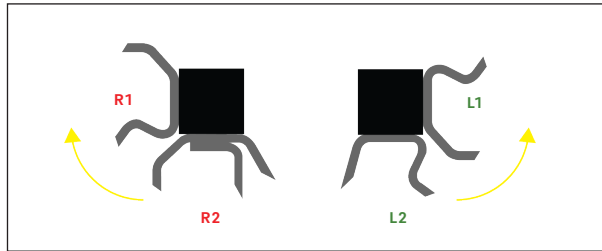

Using three of the longer M12 bolts and lock washers from **hardware kit 450470 ④**, install the two **R2** plates on the **right roll**.

**NOTE: The larger R2 plate should be installed against the shaft with the smaller R2 plate installed on the larger R2 plate. The longer M12 bolts will go through both plates.**

Using three of the shorter M12 bolts and lock washers from **hardware kit 450470 ③**, install the **L2** plate on the **left roll**.

Torque all three bolts on both the left and the right rolls to 100ft/lbs.

Rotate the head as it would in normal operation to access the next face of the shaft.

## STEP 4 INSTALL R3 AND L3

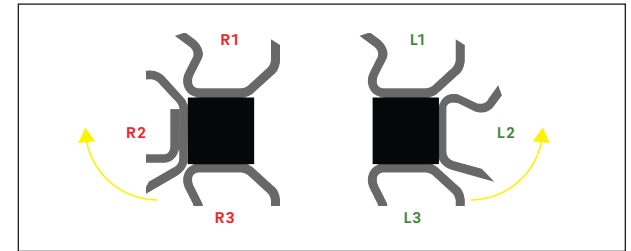

Using three of the shorter M12 bolts and lock washers from **hardware kit 450470 ③**, install the **R3** plate on the **right roll**.

Using three of the shorter M12 bolts and lock washers from **hardware kit 450470**, install the **L3** plate on the **left roll**.

Torque all three bolts on both the left and the right rolls to 100ft/lbs.

Rotate the head as it would in normal operation to access the last face of the shaft.

# INSTALLATION INSTRUCTIONS

GERINGHOFF NORTHSTAR • THREADED SHAFT



## STEP 5 INSTALL R4 AND L4

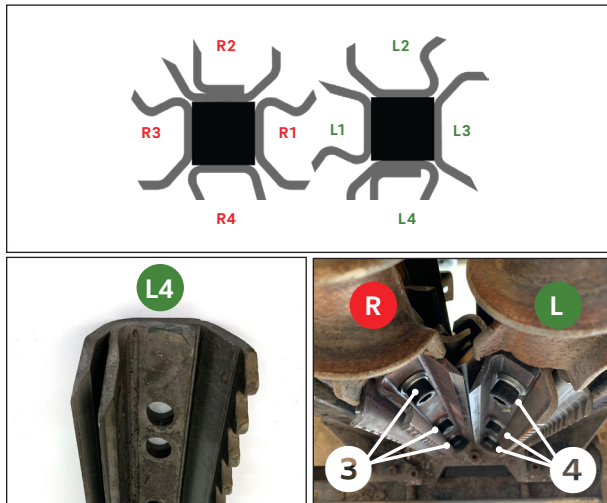

Using three of the shorter M12 bolts and lock washers from hardware kit 450470 ①, install the **R4** plate on the **right roll**.

Using three of the longer M12 bolts and lock washers from hardware kit 450470 ②, install the two **L4** plates on the **left roll**.

**NOTE:** The larger **L4** plate should be installed against the shaft with the smaller **L4** plate installed on the larger **L4** plate. The longer M12 bolts will go through both plates.

Torque all three bolts on both the left and the right rolls to 100ft/lbs.

## STEP 6 INSTALL RESIDUE KNIVES

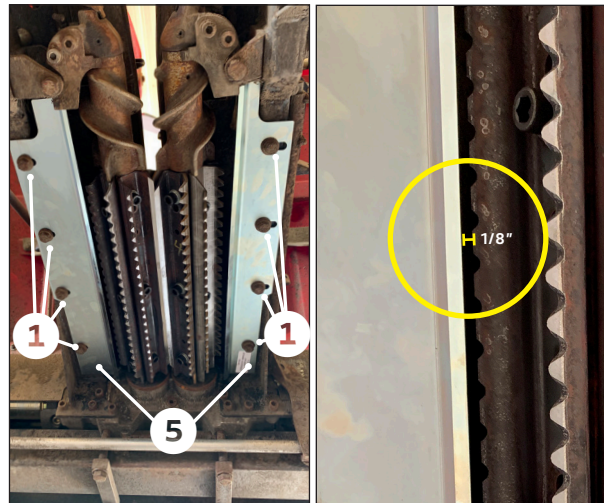

Using previously removed hardware ① install the 360 residue knives ⑤.

**NOTE:** Before completely tightening, ensure there is approximately  $\frac{1}{8}$ " gap between the residue knife and the 360 CHAINROLL plates.

Repeat steps 1-6 for the remaining rows.

## INSTALLATION COMPLETE

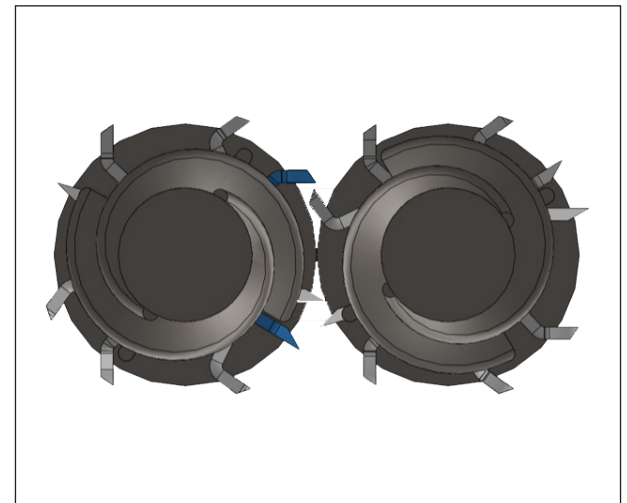

**NOTE:** Ensure cutting flutes are properly timed. As long as matching knives (R1 and L1, R2 and L2, etc) are adjacent to each other and the single cutting flute goes in between dual cutting flutes on the opposite roll, the rolls should be timed correctly.

Refer to normal OEM procedure for further adjustments.

# INSTALLATION INSTRUCTIONS

GERINGHOFF NORTHSTAR • NON-THREADED (THROUGH) SHAFT



## BEFORE YOU BEGIN



The following instructions are for Geringhoff rows with a **non-threaded shaft**. For installation instructions for rows with a threaded shaft please refer to pages 2-4.

### HELPFUL TOOLS

- 10 mm hex shaft driver
- 19 mm wrench
- 16 mm and 17 mm sockets

### NEED HELP?

Call our Product Support team at 309-300-3120.

## STEP 1

### OEM ROLL DISASSEMBLY

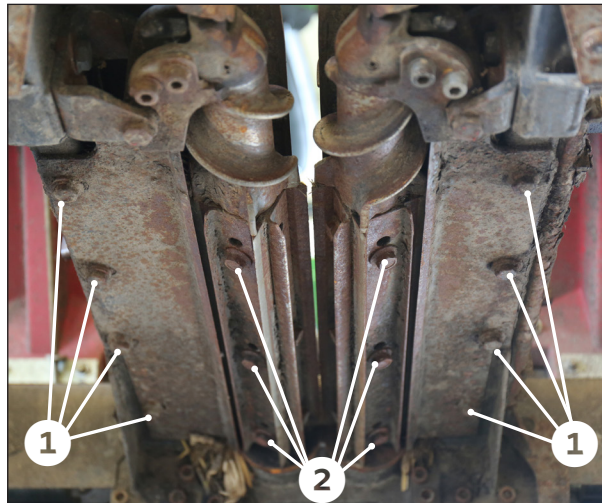

We have found the best way to install 360 CHAINROLL is by removing the residue knives and replacing the OEM roll knives with 360 CHAINROLL from the bottom side of the head.

On each row where 360 CHAINROLL will be installed, remove the four bolts **1** on each OEM residue knife. Retain these bolts for use when installing the 360 Residue Knives later in the installation process.

Remove the three bolts **2** in each OEM plate to uninstall all OEM plates on each row where 360 CHAINROLL will be installed. To gain access to all four sides of each shaft, the rolls may need to be rotated multiple times. This hardware can be discarded.

## BEFORE YOU BEGIN ASSEMBLY

### PLEASE NOTE

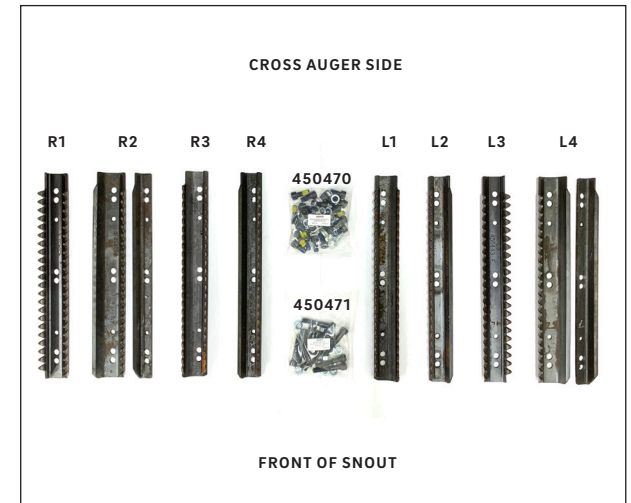

We recommend opening **only one row at a time**. Layout one bundled left kit and one bundled right kit under each row, keeping in mind that **left and right are determined from the operator's seat**.

Arrange the knives as shown in the picture above:

R1 - R2 (consists of two pieces) - R3 - R4

L1 - L2 - L3 - L4 (consists of two pieces)

**NOTE: The stamped numbers indicated the back of the knife which should be oriented towards the cross auger side of the head.**

For assembly on non-threaded shafts, use the hardware from **hardware kit 450471** with the washers from **hardware kit 450470**.



# INSTALLATION INSTRUCTIONS

GERINGHOFF NORTHSTAR • NON-THREADED (THROUGH) SHAFT



## STEP 2 INSTALL R1 AND R3

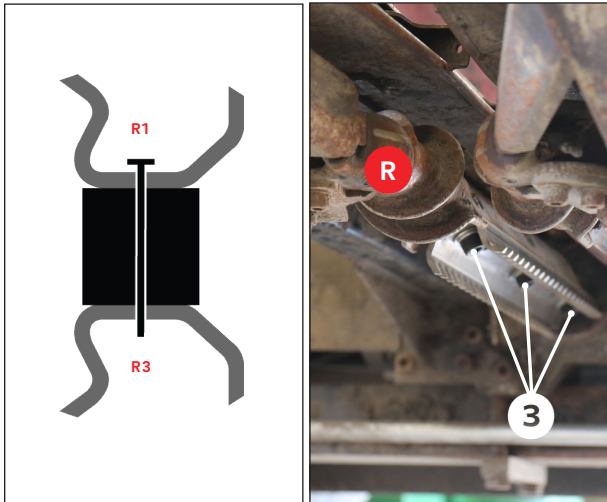

Using three of the shorter through bolts from **hardware kit 450471 ③** and three of the lock washers and flat washers from **hardware kit 450470** install the **R1** plate on the **right roll**.

On the opposite side of the right roll install the **R3** plate on the through bolts from **R1** and secure with the nuts from **hardware kit 450471**.

Torque all three bolts to 100ft/lbs.

## STEP 3 INSTALL L1 AND L3

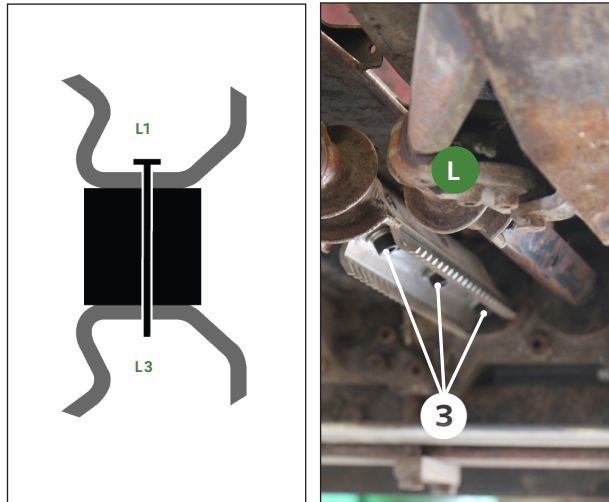

Using three of the shorter through bolts from **hardware kit 450471 ③** and three of the lock washers and flat washers from **hardware kit 450470** install the **L1** plate on the **left roll**.

On the opposite side of the left roll install the **L3** plate on the through bolts from **L1** and secure with the nuts from **hardware kit 450471**.

Torque all three bolts to 100ft/lbs.

Rotate the head as it would in normal operation to access the remaining faces of the shafts.

## STEP 4 INSTALL R2 AND R4

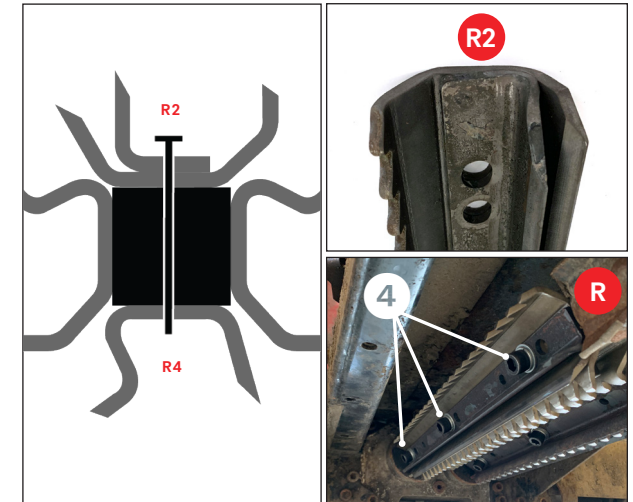

Using three of the longer through bolts from **hardware kit 450471 ④** and three of the lock washers and flat washers from **hardware kit 450470** install the two **R2** plates on the **right roll**.

**NOTE:** The larger **R2** plate should be installed against the shaft and the smaller **R2** plate is installed on top of the larger **R2** plate.

On the opposite side of the **right roll**, install the **R4** plate on the through bolt from **R2** and secure with the nuts from **hardware kit 450471**.

Torque all three bolts to 100ft/lbs.

# INSTALLATION INSTRUCTIONS

GERINGHOFF NORTHSTAR • NON-THREADED (THROUGH) SHAFT



## STEP 5 INSTALL L2 AND L4

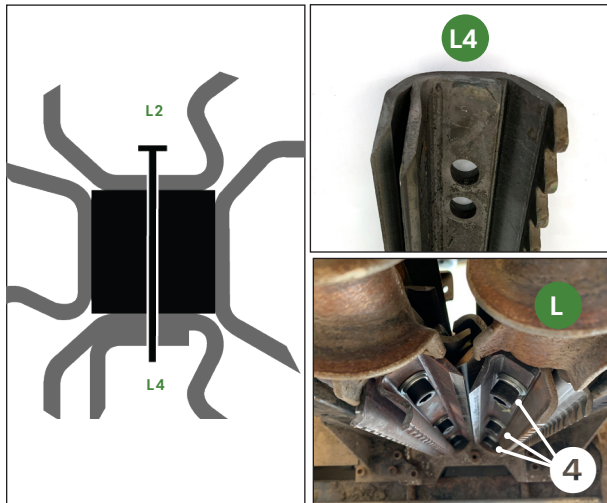

Using three of the longer through bolts from **hardware kit 450471** ④ and three of the lock washers and flat washers from **hardware kit 450470** install the **L2** plate on the **left roll**.

On the opposite side of the **left roll**, install the two **L4** plates on the through bolt from **L2**.

**NOTE:** The **L4** plate should be installed against the roll and the **L4** plate should be installed on the larger **L4** plate.

Secure with the nuts from **hardware kit 450471**.

Torque all three bolts to 100ft/lbs.

## STEP 6 INSTALL RESIDUE KNIVES

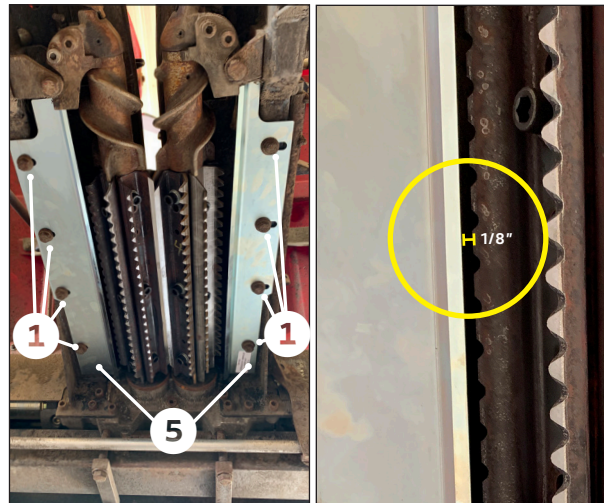

Using previously removed hardware ① install the 360 residue knives ⑤.

**NOTE:** Before completely tightening, ensure there is approximately **1/8"** gap between the residue knife and the 360 CHAINROLL plates.

Repeat steps 1-6 for the remaining rows.

## INSTALLATION COMPLETE

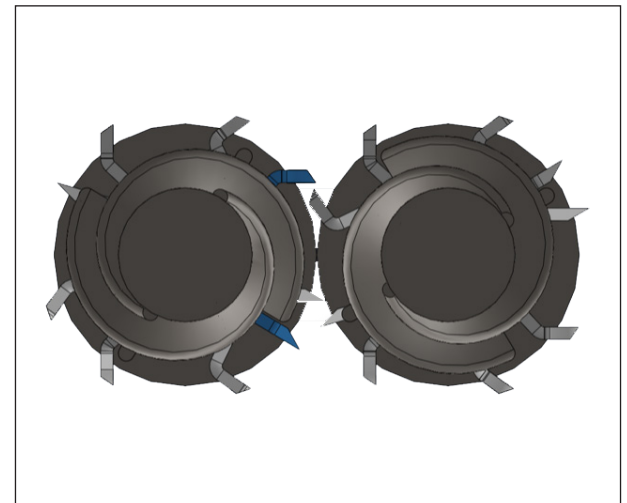

**NOTE:** Ensure cutting flutes are properly timed. As long as matching plates (R1 and L1, etc.) are adjacent to each other and the single cutting flute goes in between dual cutting flutes on the opposite roll, the rolls should be timed correctly.

Refer to normal OEM procedure for further adjustments.