

360 SPRINT



# 360 SPRINT™

INSTALLATION INSTRUCTIONS  
JOHN DEERE GATOR 835 AND 865



[360YIELDCENTER.COM](http://360YIELDCENTER.COM)

FOR QUESTIONS PLEASE CONTACT OUR  
PRODUCT SUPPORT TEAM AT 309-300-3120





# TABLE OF CONTENTS

<b>PARTS OVERVIEW.....</b>	<b>PAGE 3</b>
<b>STEP 1   REMOVE GATOR BED.....</b>	<b>PAGE 4</b>
<b>STEP 2   INSTALL TANK MOUNT BRACKETS.....</b>	<b>PAGE 4</b>
<b>STEP 3   INSTALL WHEEL SPACER ASSEMBLIES.....</b>	<b>PAGE 5</b>
<b>STEP 4   CONNECT HITCH MOUNT ASSEMBLY. ....</b>	<b>PAGE 5</b>
<b>STEP 5   INSTALL BATTERY CABLE AND CAB HARNESSING. ....</b>	<b>PAGE 6</b>
<b>STEP 6   INSTALL WHEEL ASSEMBLIES.....</b>	<b>PAGE 7</b>
<b>STEP 7   INSTALL SPRINT TANK FRAME.....</b>	<b>PAGE 8</b>
<b>STEP 8   INSTALL BOOM MOUNT.. ....</b>	<b>PAGE 9</b>
<b>STEP 9   INSTALL BOOM.....</b>	<b>PAGE 10</b>
<b>STEP 10   ROUTE WINCH STRAP. ....</b>	<b>PAGE 10</b>
<b>STEP 11   ROUTE PLUMBING TO BOOM.. ....</b>	<b>PAGE 11</b>
<b>STEP 12   ROUTE AIRLINE HOSE .....</b>	<b>PAGE 12</b>
<b>STEP 13   INSTALL TANK VENT AND FILL PORT. ....</b>	<b>PAGE 12</b>
<b>STEP 14   INSTALL CONTROL PANEL. ....</b>	<b>PAGE 13</b>
<b>STEP 15   ROUTE MAIN HARNESSING. ....</b>	<b>PAGE 13</b>
<b>STEP 16   MOUNT PLANTER FUNNEL (JOHN DEERE).....</b>	<b>PAGE 14</b>
<b>STEP 16   MOUNT PLANTER FUNNEL (CASE IH).....</b>	<b>PAGE 15</b>

# PARTS OVERVIEW



TANK MOUNT BRACKETS



BOOM MOUNT



CONNECTION HITCH



WHEEL SPACER ASSEMBLIES



SUPPORT STRAPS



LINKAGES



- A** STRAIGHT HOSE BARB
- B** 2" MANIFOLD FLANGE CLAMP
- C** 2" RUBBER GASKET
- D** T-BOLT HOSE CLAMP
- E** 90 DEGREE SWEPT FITTING
- F** 3" FLANGE 45° ADAPTER ELBOW
- G** 3" CAMLOCK CAP
- H** CONNECTOR NIPPLE - 1"
- I** 1-1/4" TO 1" REDUCER
- J** 90 DEGREE ELBOW - 1"
- K** 90 DEGREE HOSE BARB FITTING
- L** 1-1/4" NIPPLE
- M** 1-1/4" 90 DEGREE ELBOW
- N** 1/4" O.D. PUSH-TO-CONNECT COUPLER
- O** 3" MANIFOLD FLANGE CLAMP
- P** 3" RUBBER GASKET

## STEP 1 | REMOVE GATOR BED

**NOTE** If you have an electrical actuated bed, unplug electrical harness from actuator. Zip tie electrical harness out of the way.

FIGURE 1

**STEP 1A** Disconnect and remove the actuator ❶.

**STEP 1B** Disconnect tail light wiring ❷ from gator bed.

**STEP 1C** If installed, remove the safety lockout bar from the front of the bed by taking out the two bolts. Set aside for reinstallation of gator bed.

**STEP 1D** Using an 18 mm socket and wrench, remove the two bolts ❸ that secure the bed to the gator and remove the gator bed.

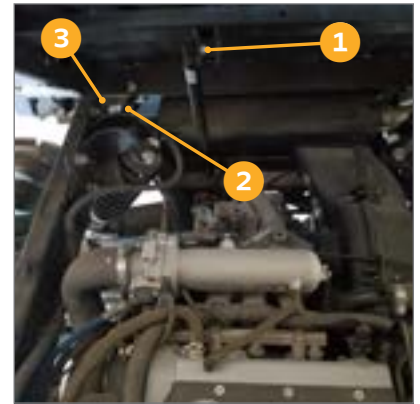

FIGURE 1

## STEP 2 | INSTALL TANK MOUNT BRACKETS (PART #530412)

FIGURE 2

**NOTE** Left and right are determined from the driver's seat. Determine left and right tank mount brackets by placing the tank mount brackets ❹ with the square tubing ❺ to the inside and attachment bracket ❻ to the front.

**STEP 2A** Starting on the left side with the attachment bracket ❻ oriented as shown, slide tank mount bracket ❹ over the left side of the gator frame at the rear of the gator bed.

FIGURE 3

**STEP 2B** Install shorter 1.75" spacer ❷ between the two holes at the back of the tank mount bracket and insert 7/16" x 3" bolt with washer ❸ through the brackets and spacer ❷, secure with another 7/16" washer and nylock nut.

**STEP 2C** Insert the longer 2" spacer in the front hole of the bracket, insert 7/16" x 3" bolt with washer ❹ through the bracket and spacer, secure with another 7/16" washer and nyloc nut.

**STEP 2D** Repeat on right side.

**NOTE** Ensure OEM tail light harness is in an easily accessible location. It will be connected to harness at a later step.

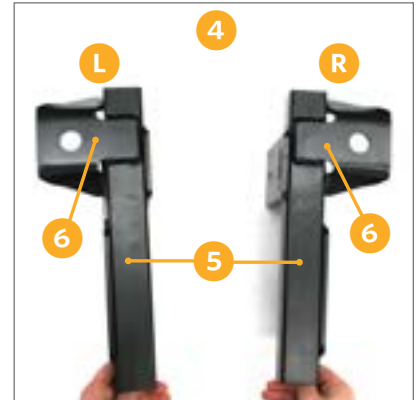

FIGURE 2

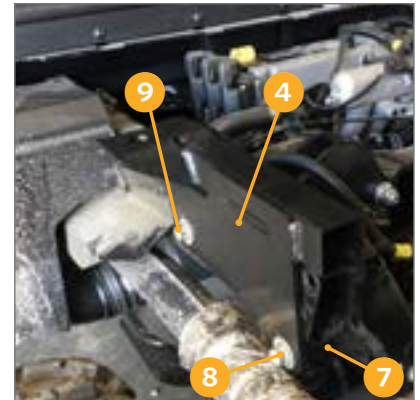

FIGURE 3 | LEFT SIDE SHOWN

## STEP 3 | INSTALL WHEEL SPACER ASSEMBLIES

**NOTE** Spacers are required on the original axles to center the gator in the rows. (The system was designed on a 60" center for 20" and 30" rows. For use with other row spacing please call product support.)

**NOTE** When removing and reinstalling wheel assemblies, refer to OEM operators manual for wheel bolt torque values and installation guidelines.

FIGURE 4

**NOTE** It is recommended to adjust the front and rear coil tension on the suspension to the heaviest setting ⑩ using the factory supplied spanner wrench.

**STEP 3A** Remove rear wheel assemblies.

FIGURE 5

**STEP 3B** Install (10) 7/16" x 3/4" bolts to secure 4" spacers ⑪ to the rear axle hubs. Tighten with 19mm socket. Torque bolts to OEM spec.

**STEP 3C** Reinstall the rear wheel assemblies using the OEM bolts. Torque bolts to OEM spec.

**STEP 3D** Remove front wheel assemblies.

FIGURE 6

**STEP 3E** Install (10) 7/16" x 3/4" bolts to secure 4" spacers ⑫ to the front axle hubs. Tighten with 19mm socket. Torque bolts to OEM spec.

**STEP 3F** Reinstall the front wheel assemblies using the OEM bolts. Torque bolts to OEM spec.

## STEP 4 | CONNECT HITCH MOUNT ASSEMBLY

FIGURE 7

**STEP 4A** Slide hitch mount assembly ⑬ into the rear 2" receiver. Align the front hole in the mount assembly with the pin hole on the gator receiver.

**STEP 4B** Install the provided 5/8" pin through both pieces and secure with hairpin ⑭.



FIGURE 4



FIGURE 5



FIGURE 6

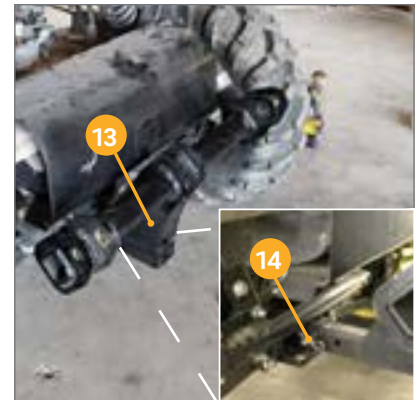

FIGURE 7

## STEP 5 | INSTALL BATTERY CABLE AND CAB HARNESSING

FIGURE 8

**STEP 5A** Remove the air filter box. Use 10mm wrench and socket to loosen the top bolt 15 that holds the air box strap. Lift filter out of the way.

FIGURES 9 & 10

**STEP 5B** Using harness 530942, attach the eyelet of the black wire 16 to the ground (negative terminal) on the battery. Attach the eyelet of the red wire 17 to the positive power terminal on the battery or to the remote charging post.

**STEP 5C** Route the connector plug above the air filter box and reinstall the air filter box.

**STEP 5D** Using a 1-5/8" hole saw, drill a hole through the panel behind the driver's seat approximately 5-1/2" from the inside edge of the panel and 2-1/4" from top edge of the panel.

FIGURE 11

**STEP 5E** Install harness 530903 18 through the hole on the inside of the cab. Secure with spring washer and retaining nut 19 from the back of the cab. This harness will later get attached to harness 530940 (main SPRINT harness).

**NOTE** The cap that comes attached to harness 530903 is used to cap the harness when SPRINT is uninstalled. The cap will be attached on the outside to harness 530903.

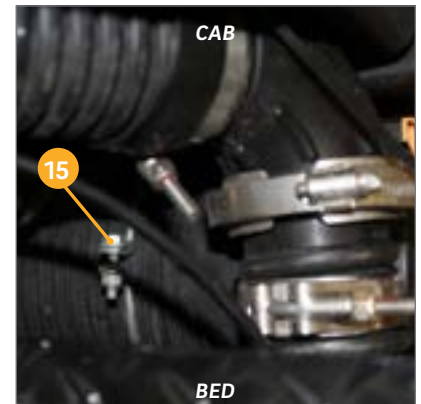

FIGURE 8



FIGURE 9

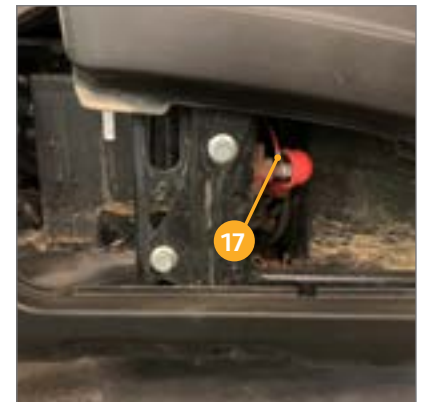

FIGURE 10

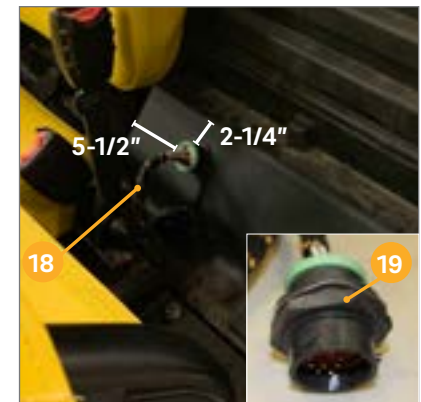

FIGURE 11

## STEP 6 | INSTALL WHEEL ASSEMBLIES

**NOTE** When removing and reinstalling wheel assemblies, refer to OEM operators manual for wheel bolt torque values and installation guidelines.

FIGURE 12

**STEP 6A** While the SPRINT tank frame is still on the shipping pallet, remove the (5) 7/16" nuts 20 from the hub of the axel on the SPRINT tank frame.

FIGURE 13

**STEP 6B** Install the gator wheel assemblies 21 (that were purchased separately) onto the hub studs and secure them with the previously removed nuts. Tighten with 3/4" socket and torque to OEM specs.

**NOTE** To install the wheel assemblies, the SPRINT tank frame may need to be lifted.



FIGURE 12



FIGURE 13

## STEP 7 | INSTALL SPRINT TANK FRAME

FIGURE 14

**STEP 7A** Attach linkage **22** to the welded bracket on the side of the SPRINT tank frame. Slide  $\frac{3}{4}$ " x 4-1/2" pin **23** through the bracket holes and linkage. Secure with lynch pin **24**.

**STEP 7B** Repeat on the other side.

FIGURE 15

**STEP 7C** From hardware kit 530923, slide small bushing **25** inside of the large rubber bushing **26**.

FIGURE 16

**NOTE** There will be two large washers in each hardware kit but only one large washer will be used on each side.

**STEP 7D** Roll the SPRINT tank frame forward onto the gator bed. With SPRINT tank frame resting on the gator frame, secure tank frame to gator frame using  $\frac{1}{2}$ " bolt, spacers, and washers from hardware kit 530923 in the following order:

Bolt **27**

Small Washer **28**

Tank Frame Bracket **29**

Large Washer **30**

Large Rubber Bushing with steel standoff facing down **26**

Attachment Bracket **6**

Small Rubber Spacer **31**

Small Metal Washer **32**

Nyloc Nut **33**

**STEP 7E** Tighten with  $\frac{3}{4}$ " socket and wrench.

**STEP 7F** Repeat on the other side.

FIGURE 17

**STEP 7G** Attach the other end of the linkage to the arm on the hitch mount assembly using  $\frac{3}{4}$ " x 4-1/2" pin and secure with lynch pin **34**.

**STEP 7H** Repeat on the other side.

**NOTE** When the SPRINT tank is full, there should be approximately 40% of the gross vehicle weight on the SPRINT axle (rear axle).

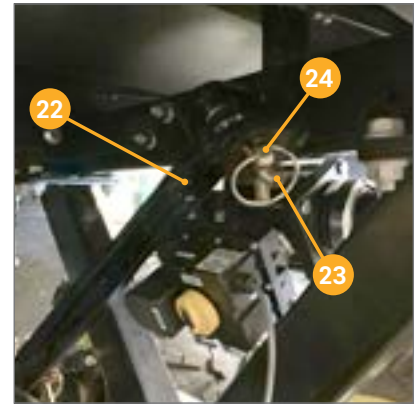

FIGURE 14



FIGURE 15

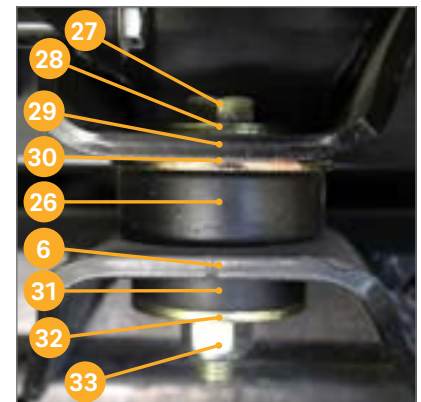

FIGURE 16

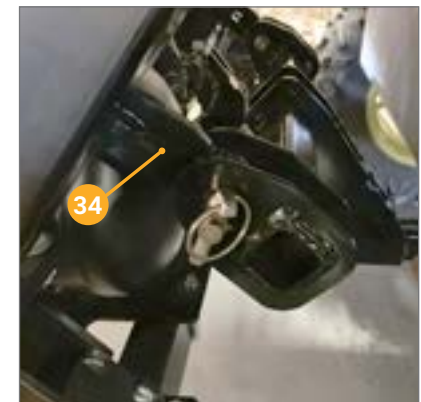

FIGURE 17



## STEP 8 | INSTALL BOOM MOUNT (PART #530694)

**NOTE** Before continuing, remove any attachments from front of gator. Remove the two black plastic trim pieces that cover the front mounting brackets and the front grill guard.

FIGURE 18

**STEP 8A** Secure winch bracket 35 to boom mount 36 with supplied 3/8"x2" u-bolts, 3/8" washers and nuts 37 from hardware kit #530812. Tighten with 9/16" socket.

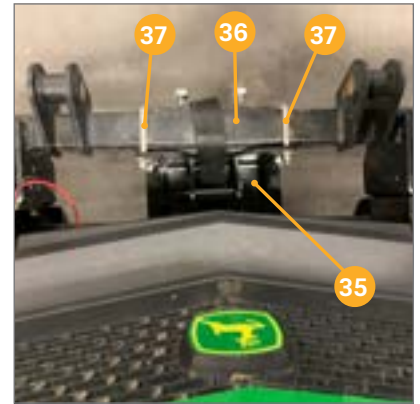

FIGURE 18

FIGURE 19

**STEP 8B** Slide bottom tube 38 of boom mount into the receiver 39 on the front of the gator ensuring the winch mount slides into the area between attachment brackets. Install 5/8"x3" hitch pin 40 through the front hole on the receiver and secure with hairpin clip.

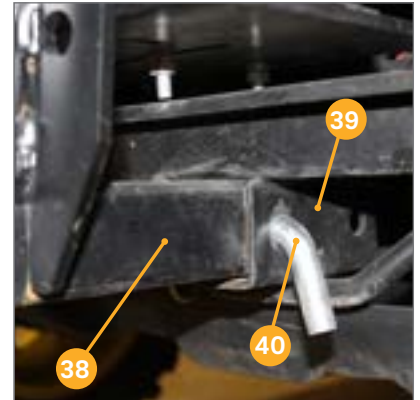

FIGURE 19

FIGURE 20

**STEP 8C** Secure the top of the boom mount to the front of the gator by installing (2) 3/8" x 1-1/4" flange bolts 41 through boom attachment bracket and boom mount. Secure with 3/8" washer and nylock nut. Tighten with 9/16" socket and wrench.

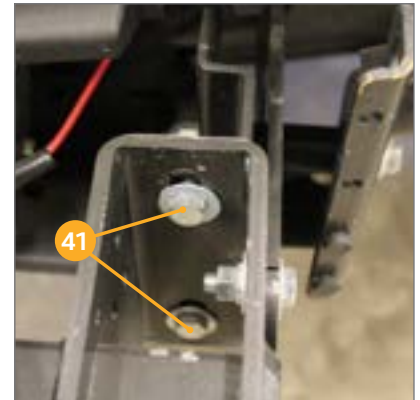

FIGURE 20

**STEP 8D** Repeat on the other side.

FIGURE 21

**STEP 8E** Attach support straps 42 to the outside of the top of the boom mount with (3) 3/8" x 1-1/4" flange bolt and secure with 3/8" washer and nylock nut 43. Tighten with 9/16" socket and wrench. Place a 3/8" x 2" square u-bolt 44 over the rectangular support frame 45 under the front of the gator to secure the back of the support strap. Secure with 3/8" washer and nylock nut. Tighten with 9/16" socket.

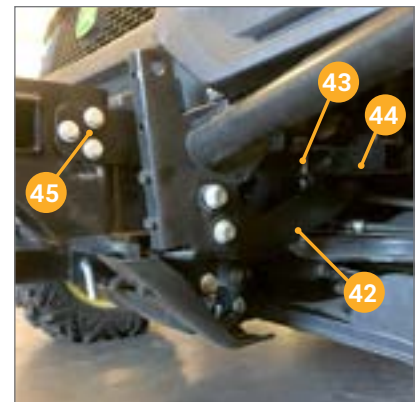

FIGURE 21

**STEP 8F** Repeat on the other side.

**STEP 8G** Install 1/2" x 3" bolts in the holes on the front of the boom mount. These bolts are used as a bottom stop for the boom. Thread them in to desired boom travel.

## STEP 9 | INSTALL BOOM

**STEP 9A** Remove pins from boom pivot mount brackets.

FIGURE 22

**STEP 9B** Align pivot mount brackets on boom **46** with those on the boom mount **47**. Slide 1"x 4" pin **48** through both pieces to secure them together. Insert lynch pin **49**.

FIGURE 23

**STEP 9C** Install the liquid pressure gauge **50** and the air pressure gauge **51** on the tee fitting using Teflon tape and 9/16" wrench.

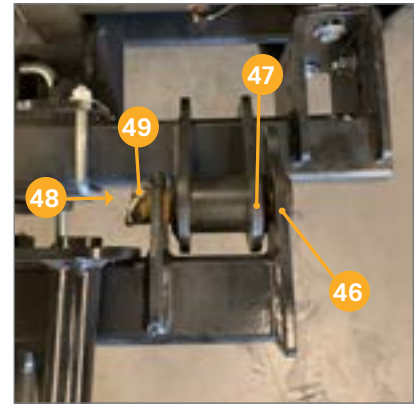

FIGURE 22

## STEP 10 | ROUTE WINCH STRAP

FIGURE 24

**STEP 10A** Pull the strap **52** out until it is fully extended.

**STEP 10B** Route the strap under the plastic roller **53**, over the top of the large roller and back down to pin. Secure the bottom of the strap by installing the 1/2" pin through bracket **54**, strap and bracket on the other side. Secure with pin with hairpin clip **55**.

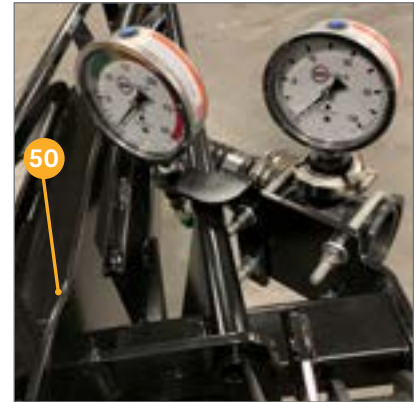

FIGURE 23

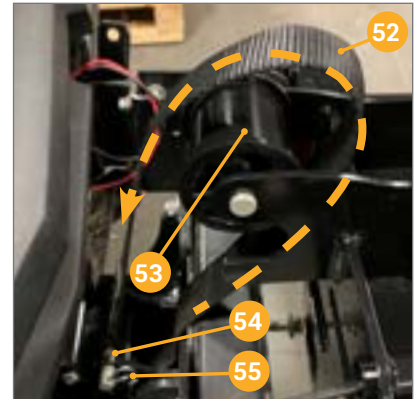

FIGURE 24

FIGURE 25

## STEP 11 | ROUTE PLUMBING TO BOOM

FIGURE 25

**STEP 11A** Attach straight hose barb to the tee on the electric on/off valve (attached to right side of the SPRINT tank frame). Secure with 2" manifold flange clamp and 2" rubber gasket **56**. Tighten with 5/16" nut driver. Secure 23' hose to barb with t-bolt hose clamp and tighten with 7/16" socket.

**STEP 11B** Route hose to the front of the SPRINT tank frame. Cut the hose to length (use a length that will be convenient for disassembly of SPRINT frame from gator).

**STEP 11C** Attach the swept 90 degree to straight hose barb using 2" manifold flange clamp and 2" rubber gasket **57**. Tighten with 5/16" nut driver. Secure cut hose to straight hose barb with t-bolt hose clamp and tighten with 7/16" socket **58**.

**STEP 11D** Attach the remainder of the 23' section of hose to the hose barb on the swept fitting and secure with t-bolt hose clamp and tighten 7/16" socket.

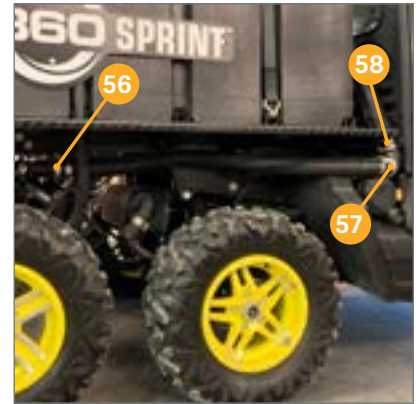

FIGURE 25

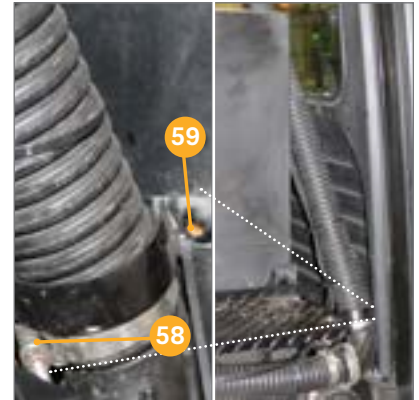

FIGURE 26

FIGURE 27

**STEP 11E** Use a p-clamp to secure the hose at the 90 degree swept fitting. Remove the screw (6" from cab corner) and secure p-clamp with it in that spot **59**.

FIGURE 27

**STEP 11F** Route hose over the top of the cab (route towards center of cab around protrusion) **60**, to the pressure gauge tee fitting on the boom. Cut the hose to length.

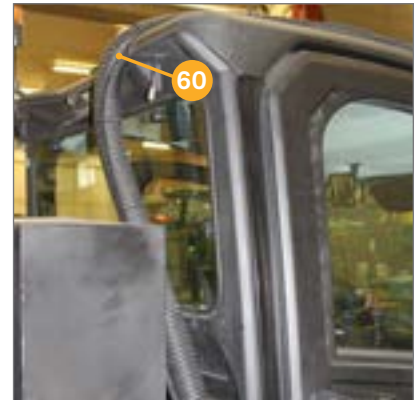

FIGURE 27

FIGURE 28

**STEP 11G** Secure hose to the door mount by removing the top right bolt. Secure p-clamp and hose to door mount with the bolt **61**.

**STEP 11H** Attach hose barb to the tee fitting with 2" manifold flange clamp and 2" rubber gasket. Tighten with 5/16" nut driver. Attach the previously cut hose to the hose barb using t-bolt hose clamp and tighten with 7/16" socket **62**.

**NOTE** Ensure to leave slack for boom movement up and down.



FIGURE 28

## STEP 12 | ROUTE AIRLINE HOSE

FIGURE 29

**STEP 12A** Using the ¼" air hose that is coiled on the right hand fender, cut the hose at the cab and install a ¼" O.D. push to connect coupler. Install the remainder of the hose into the other side of the coupler **63**. Route hose along the 2" liquid hose you just installed, over the cab. Zip tie to hose along the way.

FIGURE 30

**STEP 12B** Route the hose to the front pressure gauge tee, trim the hose to length. Attach the hose coming out of the end of the boom with the hose previously cut using ¼" O.D. push to connect coupler **64**.

**NOTE** The couplers allow the SPRINT frame and boom to be removed from gator without removing all of the plumbing.

## STEP 13 | INSTALL TANK VENT AND FILL PORT

**NOTE** Apply thread sealant to ALL flange fittings prior to install.

FIGURE 31

**STEP 13A** Using 530736 tank vent assembly kit, install 1-1/4" to 1" reducer **65** into the 1-1/4" tank bung on top of tank. Assemble 1" x 4" connector nipple **66** into reducer. Install T-fitting **67** on the top of the connector. Thread 90 degree hose barb fitting **68** into one end of the T-fitting. Thread the check valve into the other end of the T-fitting, ensuring the flow directional arrow is pointed toward the T-fitting.

**STEP 13B** Secure 1-1/4" EPDM hose onto hose barb with supplied hose clamp and use 5/16" nut driver to tighten. Route hose to the right side of the tank and down the side behind the 360 SPRINT decal plate. Along the tank frame to the underside of the axle and trim to length. Secure hose to the tank frame with zip ties **69**.

**STEP 13C** Install 1-1/4" nipple & 1-1/4" 90 degree elbow to the tank vent line bung on the inside of the tank. This helps prevent sloshing into the vent line.



FIGURE 29



FIGURE 30

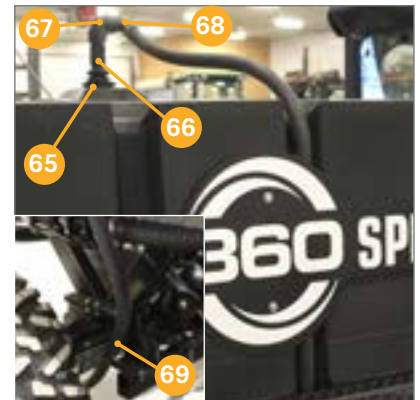

FIGURE 31

## STEP 14 | INSTALL CONTROL PANEL

FIGURE 32

**STEP 14A** Fasten the u-bolt mount on the handle bar in the gator cab. Secure nuts on u-bolts with 7/16" socket **72**. Use ram extension **73** to mate the handle bar mount to the ball mount of the control box.

**NOTE** If your gator with equipped with a mounting ball you can mount the ram extension to the factory supplied mounting ball securing the control box in that location.



FIGURE 32

## STEP 15 | ROUTE MAIN HARNESSING

**NOTE:** Before routing any harnessing, ensure the red electrical disconnect switch has been turned to the off position.

FIGURE 33

**STEP 15A** On the front left hand of the SPRINT tank frame, remove wiring harness from plastic bag. Connect 14pin cab connector to harness 530903 (previously installed in step 5) for power to the control box **74**.

**STEP 15B** Route the remaining harness with two connectors along the front of the tank frame between the cab and SPRINT system. Connect the 2 pin receptacle to the battery harness plug previously installed.

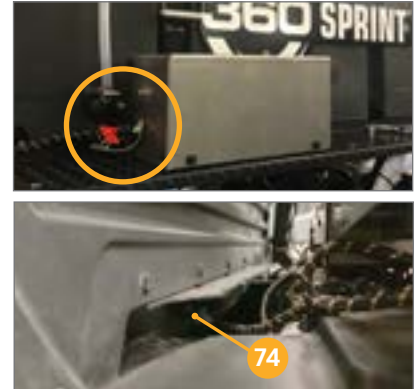

FIGURE 33

FIGURE 34

**STEP 15C** Connect the winch extension harness 530516 to the plug connector on the main harness and route it along the 2" liquid hose to the front of the cab. Route under the hood and connect to mating winch harness **75**. Secure harness along the way with zipties.



FIGURE 34

FIGURE 35

**STEP 15D** Attach factory tail light harness to SPRINT tail light harness found along Sprint frame on each side **76**.

**NOTE** For later model gators, 8" tail light adapter harness will not be needed.



FIGURE 35

## STEP 16 | MOUNT PLANTER FUNNEL

### JOHN DEERE PLANTER

FIGURES 36 - 39

**STEP 16A** Remove the four bolts on the faceplate of the row unit and discard. Install the funnel mount plate (530708) on the face plate using the hardware provided in kit 530815 **77**.

**NOTE** If row cleaners are installed, position the funnel mount plate between the row unit faceplate and the row cleaners.

**STEP 16B** Remove the top/outside bolt from the parallel arm **78**. Retain one bushing. Utilizing 5/8" x 3-1/2" bolt, large bushing **79**, and nut from hardware kit 530815, reconnect parallel arm with "step down" bushing on the outside (large end closest to parallel arm).

**NOTE** Ensure that the check valve arrow is pointing in the direction of flow.

**STEP 16C** Hang funnel from bushing **80** and secure to funnel mount plate with 1/2" x 5" carriage bolt, lock washer, and threaded knob **81**.

**STEP 16D** Install fittings onto funnel in this order; camlock fitting **82**, check valve **83**, barbed fitting **84**. Secure each fitting together with 2" rubber gasket **85** and 2" manifold flange clamp **86**. Tighten with 5/16" nut driver.

**STEP 16E** Install the hose to the barbed fitting and secure with t-bolt hose clamp **87**. Tighten with 7/16" socket.

FOR INSTALLATION ON A CASE IH PLANTER, SEE NEXT PAGE

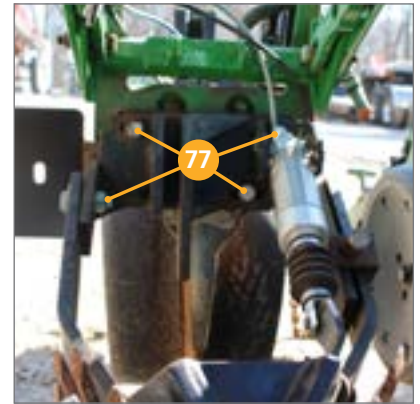

FIGURE 36



FIGURE 37

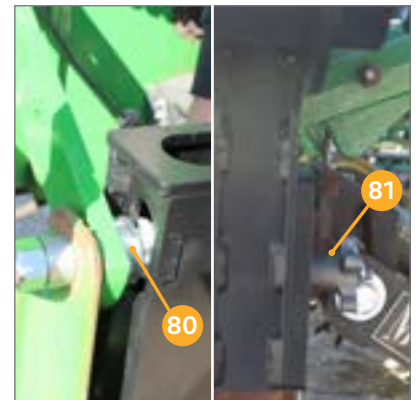

FIGURE 38



FIGURE 39

## STEP 16 | MOUNT PLANTER FUNNEL

### CASE IH PLANTER

FIGURES 40-43

**STEP 16A** Remove the two bolts 88 on the front of the row unit. Install the funnel mount bracket on the front of the row unit using the (2) 1/2"x3-1/2" bolts with washers and nuts provided in hardware kit 530859.

**NOTE** If row cleaners are being used, they must be removed to install the funnel mount break. The row cleaners can then be reinstalled on the funnel mount bracket using the previously removed hardware.

**STEP 16B** Remove the top/outside bolt from the parallel arm 89. Utilizing 1/2" x 3" bolt, large bushing 90, and nut from hardware kit 530859, reconnect parallel arm with "step down" bushing on the outside (large end closest to parallel arm).

**NOTE** Ensure that the check valve arrow is pointing in the direction of flow.

**STEP 16C** Hang funnel from bushing 91 and secure to funnel mount bracket with 1/2" x 5" carriage bolt, lock washer, and threaded knob 92. Carriage bolt should be installed from the back, going through the funnel mount bracket first and then the funnel.

**STEP 16D** Install fittings onto funnel in this order; camlock fitting 82, check valve 83, barbed fitting 84. Secure each fitting together with 2" rubber gasket 85 and 2" manifold flange clamp 86. Tighten with 5/16" nut driver.

**STEP 16E** Install the hose to the barbed fitting and secure with t-bolt hose clamp 87. Tighten with 7/16" socket.



FIGURE 40

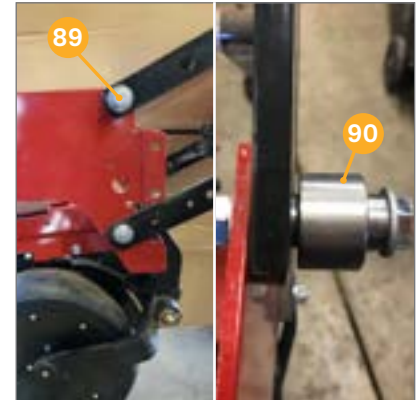

FIGURE 41



FIGURE 42



FIGURE 43