



# 360 TANKS™

INSTALLATION INSTRUCTIONS  
CASE IH LARGE FRAME MODELS



[360YIELDCENTER.COM](http://360YIELDCENTER.COM)

FOR QUESTIONS PLEASE CONTACT OUR  
PRODUCT SUPPORT TEAM AT 309-300-3120

8.18.20 • V2



# INSTALLATION INSTRUCTIONS

## CASE IH



### HELPFUL TOOLS

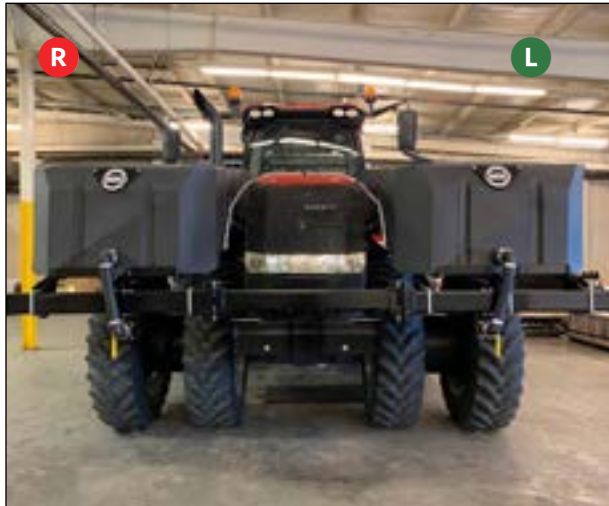

- Impact
- Socket Sizes: 30mm, 3/4", 5/16", 9/16" and 1-1/8", 1-5/16"
- 15/16" Deep Well Socket
- 5/16" Driver
- Wrench Sizes: 1-1/8", 15,16", 3/4", 9/16" and 1-5/16"
- Anti-seize
- WD-40
- Pipe Thread Sealant
- White Thread Sealing Tape

Remember right and left sides of the tractor are determined from the operator's seat.

### BEFORE YOU BEGIN...

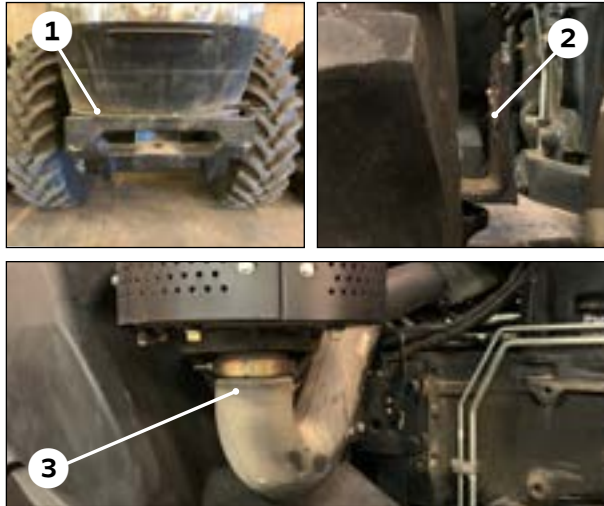

Due to the size and weight of many of the parts, this installation process will often require two people and forklift.

Before installing 360 TANKS remove the weights from the front weight bracket **1**, front fenders **2**, panel below the stack to the right of the cab **3** (retain hardware for reinstallation later), and a couple of cab lights to have proper clearance.

**NOTE: Tractor weights will not be able to be reinstalled with the 360 TANKS system installed.**

### STEP 1 FRONT MOUNT BRACKET

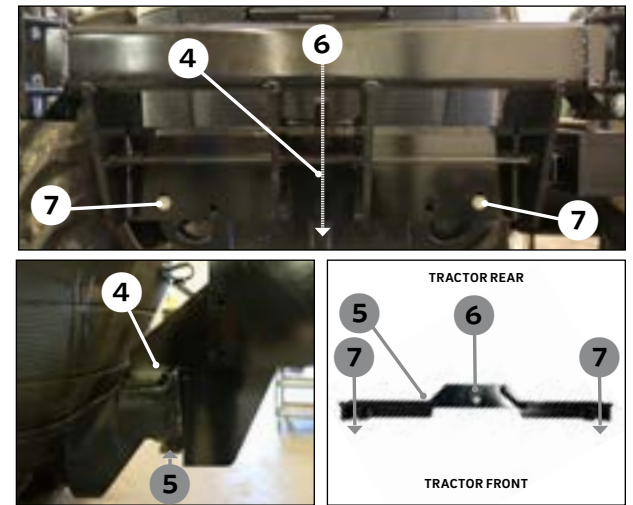

Slide the front weight bracket mount **4** over the front weight bracket casting, keeping it centered. Use the 3/4" x 10" bolt through the hole in the center of the bracket to ensure it stays in the correct position.

Install the bottom bracket **5** under the front weight mount bracket by first sliding it onto the bottom of the previously installed 3/4" x 10" bolt **6**. Loosely secure with washer and nut. Then, loosely install two horizontal bolts **7**. Once all three bolts have been installed you can tighten the center vertical bolts using 1-1/8" socket. The horizontal bolts can then be tightened using 15/16" socket and wrench.

**NOTE: To gain a little more clearance when tightening these bolts it may be helpful to open the hood of the tractor.**

Ensure that the nyloc threads are completely onto the bolt so you know it is tightened properly.

# INSTALLATION INSTRUCTIONS

## CASE IH



### STEP 2 OUTRIGGERS

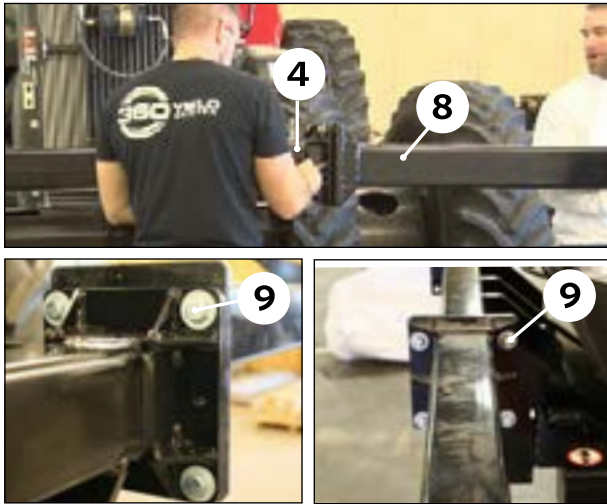

Have one person hold up the outrigger **8** aligned with the front weight bracket **4**. Loosely secure it in place using the (4)  $\frac{5}{8}$ " bolts **9** and ensuring there is a flat washer on each side of the joint. Once all 4 bolts have been inserted and loosely secured, tighten them using 15/16" socket and wrench.

**NOTE: The outrigger is offset by approximately four inches. When installing, the two flanges at the back of the joint should remain flush.**

Repeat for outrigger on the opposite side of the front weight mount bracket.

### STEP 3 REAR MOUNT BRACKETS

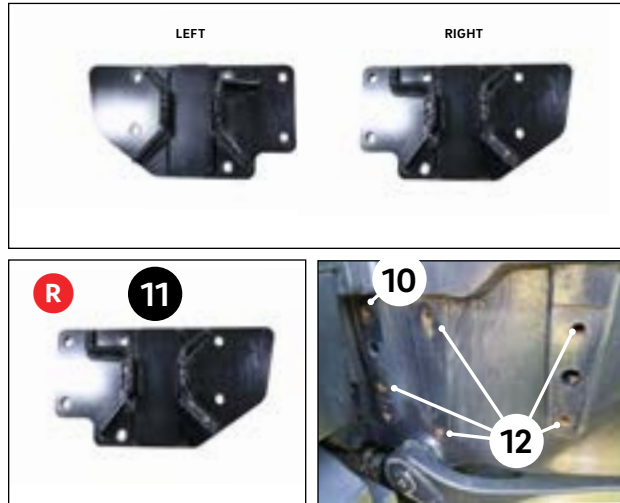

**NOTE: Left and Right mount brackets are side specific. Ensure all bracket holes align with holes on the tractor.**

**NOTE: The holes in the side casting may have plastic plugs in them which need to be removed before installing the rear mount brackets. For additional clearance during this step, it may be helpful to turn the tires completely to the left.**

On the right side of the tractor, remove bolt and spacer from the OEM mount **10** (if present). Keep the bolt as it will be re-used.

Have one person lift and align the rear mount bracket **11** with the holes in the casting on the right side of the tractor.

Loosely secure the rear mount bracket in place using the M20 bolts and washers **12**. Reuse the OEM bolt (if previously removed) with new provided spacer.

Using an 1-3/16" socket and driver, tighten all six bolts.

### STEP 3 CONTINUED REAR MOUNT BRACKETS



Repeat the process to install the rear mount bracket on the left side of the tractor.

**NOTE: There is no OEM bolt to be removed and re-used from the left side of the tractor. To install the rear mount bracket on the left side, you will use (6) M20 bolts and washers all provided in the hardware kit.**

# INSTALLATION INSTRUCTIONS

## CASE IH



### STEP 4 REAR SUPPORTS

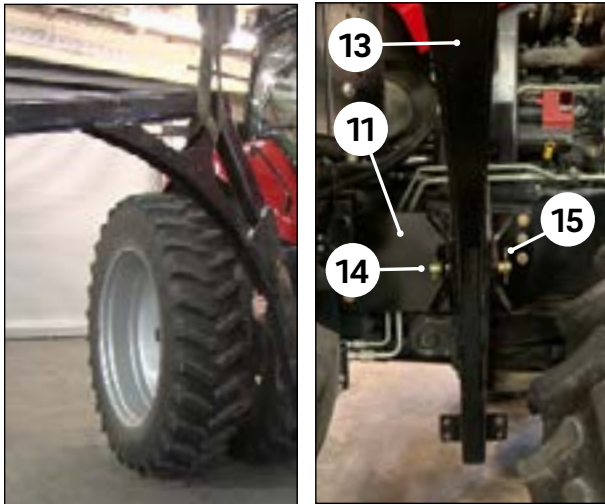

**NOTE: Use of a forklift is suggested for this step.**

With the rear support **13** strapped in the upper corner, use a forklift to move the rear support towards the rear mount bracket **11**. The second person should align the rear support with the rear mount bracket as the forklift operator moves it.

With the rear support aligned correctly with the rear mount bracket, insert the 1-1/4" pin **14** through the rear mount bracket and rear support and secure the pin with the hairpin **15**.

**NOTE: Once the rear support is secured to the rear mount bracket it will swing downward slightly. This is normal until the under tractor support is installed.**

Repeat the rear support installation process on the left side of the tractor.

### STEP 5 UNDER TRACTOR SUPPORT

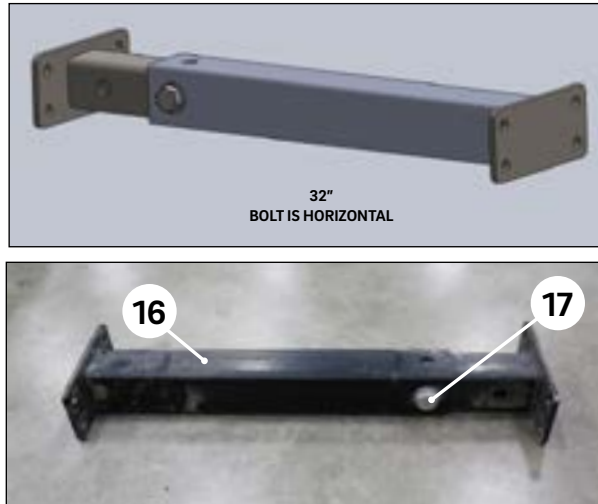

**NOTE: The under tractor support is adjustable to accommodate the wide variation of tractor sizes. Determine the length of the under tractor support needed for your tractor and adjust and secure the under tractor support at the corresponding setting. When the under tractor support is installed between the two rear supports, the top of the rear supports should be parallel to the ground.**

The under tractor support **16** should be set at the position that results in the overall length of the support being 32".

**NOTE: The holes provided for adjustment are either horizontal or vertical with the flanges. For this specific model the hole spacing is horizontal.**

Using the provided 7/8" bolt, washers and nut **17** secure the under tractor support at the required length. Tighten using 1-5/16" socket, impact and wrench.

### STEP 5 CONTINUED UNDER TRACTOR SUPPORT

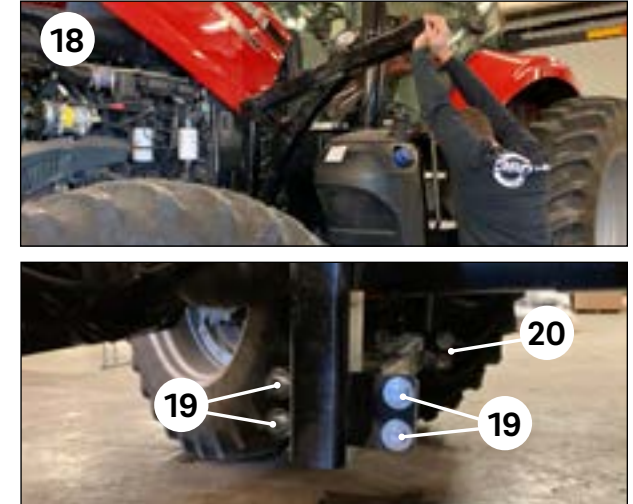

Have one person hold the rear support up in a horizontal position **18** while a second person installs the under tractor support beneath the tractor. Secure one side of the under tractor support to the rear support using the (4) 5/8" x 2-3/4" bolts, washers (one on either side of the joint), and nuts provided **19**. Tighten using 15/16" socket and impact.

Repeat the process on the opposite side **20**.

# INSTALLATION INSTRUCTIONS

## CASE IH



### STEP 6 SIDE SIGHT GAUGES

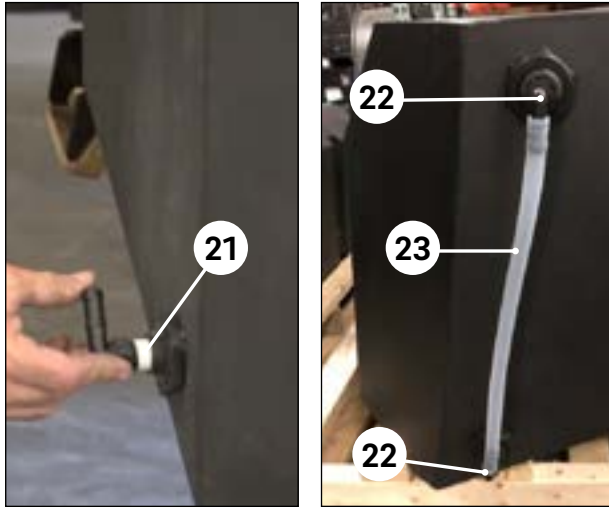

Apply white thread sealing tape to threads on each of the elbow hose fittings **21**.

On the front, inside corner of the tank, screw the elbows **22** into the side of the tank and orient towards each other.

Install the clear tube **23** between the two elbows, securing each end of the hose to the elbow with worm gear hose clamp. Ensure to insert the red float ball inside the tube before securing both ends.

Repeat for the side sight gauge on the second tank.

**NOTE: Use lubricant as needed to slide hose onto fittings.**

### STEP 7 REAR SIGHT GAUGES

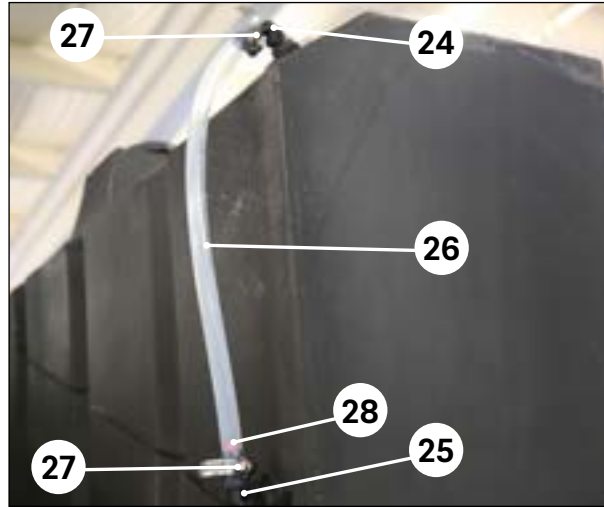

Apply white thread sealing tape to threads on each of the elbow hose fittings.

On the back side of the tank at the corner that will be closest to the tractor cab, screw the elbows into the top **24** and bottom **25** screw holes in the tank. Ensure hose barb connectors are positioned towards each other.

Install the clear tube **26** between the two elbows, securing each end of the hose to the elbow with worm gear hose clamp **27**. Ensure to insert the red float ball **28** inside the tube before securing both ends.

Repeat for rear sight gauge on second tank.

### STEP 8 VENT ASSEMBLY

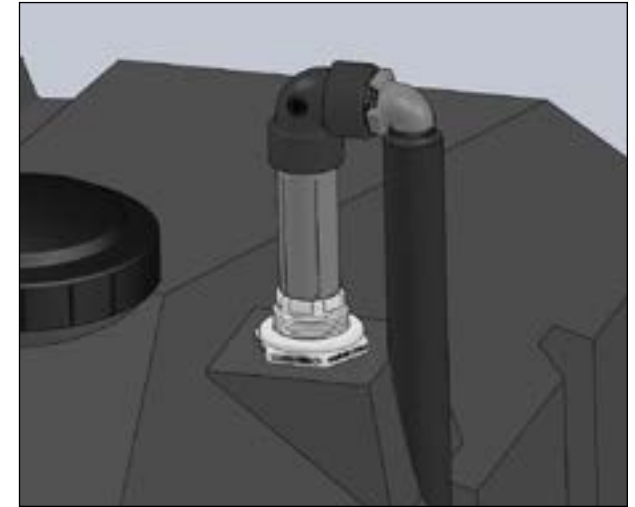

Install bottom 1- $\frac{1}{4}$ " fitting **29** into bulkhead towards the rear of the tank. Screw down to tighten and ensure port is oriented towards the rear.

Install the 1- $\frac{1}{4}$ " EPDM rubber hose to the port and let it hang down until the tanks have been properly positioned on the tractor.



# INSTALLATION INSTRUCTIONS

## CASE IH



### STEP 9 TANKS

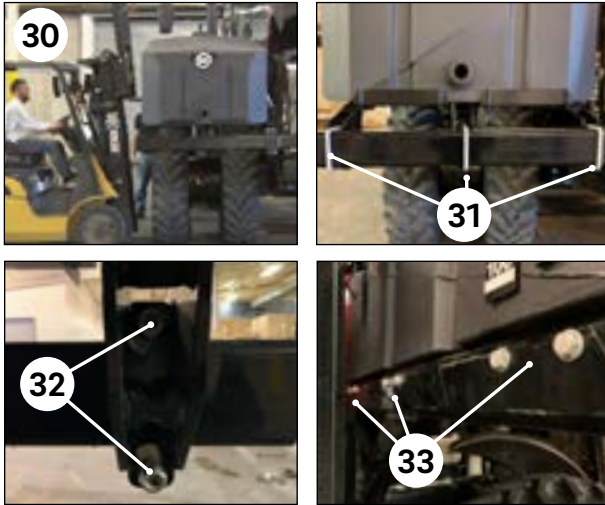

**30** Using a forklift and fork extensions, lift the first tank off the shipping pallet. Ensure forks do not stick out past the tank so that they will not come in contact with the tractor.

Place tank on front and rear supports ensuring holes on the tank support are aligned with holes on the rear support.

**NOTE: If rear support bolts do not line up, loosen the bolts that hold together the pans and support tubes under the tank to allow additional movement. Do not remove bolts completely.**

**NOTE: Situate front of the tanks first before aligning back.**

The front will sit on the front mount bracket. Loosely secure (3) front u-bolts **31** using clipped washers and 5/8" nylock nuts **32**.

Secure the rear of the tank to the rear support by loosely installing 1/2" bolts, washers (one on each side), and nuts through backside **33**. Do not tighten. Repeat for second tank.

### STEP 10 VENT HOSE

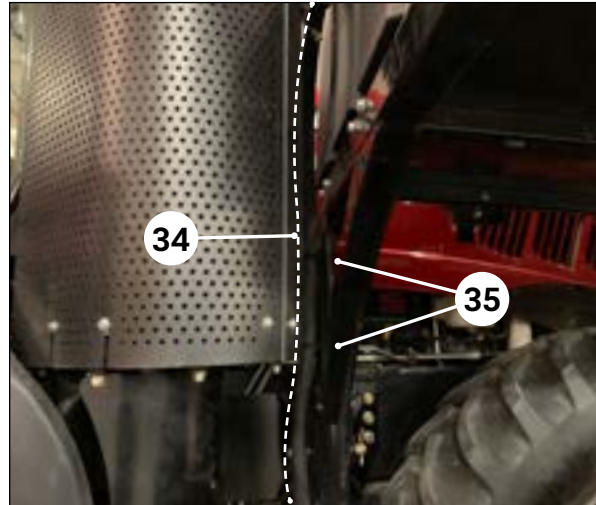

Route the 1-1/4" EPDM rubber hose **34** starting from where it is attached to the hose barb on the vent assembly continuing down along the rear support. Use zip ties to secure vent hose at multiple locations along the rear support **35**. Trim the hose as you see fit.

Repeat for vent hose on opposite tank.

### STEP 11 TIGHTEN HARDWARE

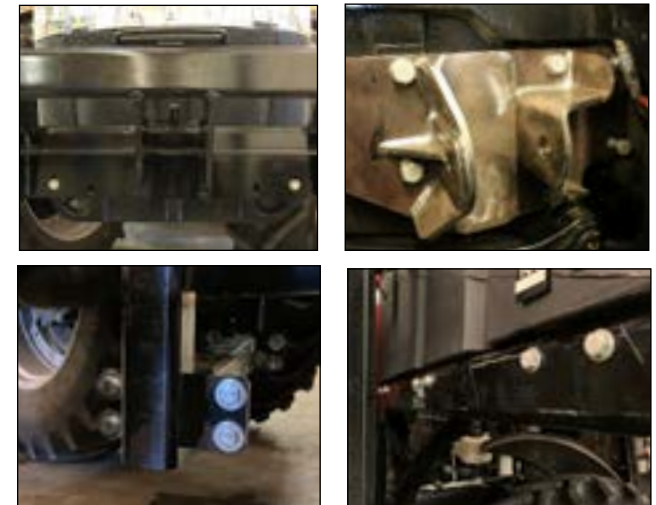

Once both tanks have been properly aligned and loosely secured, tighten **all** bolts previously left loose on both sides:

- Front Mount Bracket
- Under Tractor Support
- Rear Mount Brackets
- Tank Assembly Front U-bolts
- Tanks Assembly Rear Bolts
- Tank Assembly Pan and Support Bolts (if loosened to help with tank alignment)

# INSTALLATION INSTRUCTIONS

## CASE IH



### STEP 12 STANDARD LINES KIT



### BASIC INSTALLATION COMPLETE



**NOTE: Hose assemblies are right and left specific.**

Remove threaded flange fitting **36** from the elbow included in the hose assembly using 5/16" socket - ensuring to keep the seal and hose clamp.

Generously apply thread sealant on the threads of the flange and thread into the front of the tank **37**. Install 90 degree elbow to flange.

Install hose assembly mounting plate to front mount bar with (2) 1/2"x6" bolts, flat washers and nuts **38**. Tighten with a 3/4" socket and wrench.

Measure and cut hose to proper length up to the 90 degree elbow. Once hose is correct length for your setup, secure to flange with hose clamp.

Repeat on the second tank.

**NOTE: If the optional lines kit is being installed, please continue with the "Optional Lines Kit" installation instructions starting on the next page.**

# OPTIONAL LINES KIT INSTALLATION

## CASE IH



### STEP 1

#### 2" CENTER FILL VALVE

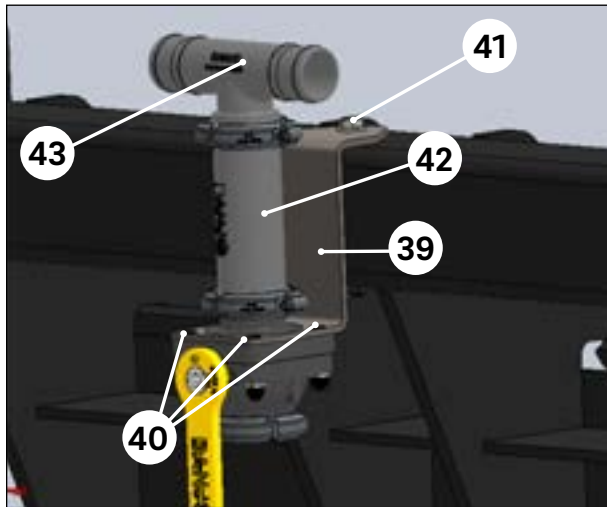

**NOTE: Ensure there is a seal between every flange connection. And, for each hose installed during this process, each end of the hose should be secured to the fitting using the provided hose clamps.**

Remove the (4) bolts from the 2" valve. Retain bolts.

Install valve bracket **39** on the backside of valve. Secure with previously removed bolts and provided flange nuts **40**.

Install 2" valve assembly to the front weight mount bracket using the bolt and provided hardware **41**.

Install the 6" pipe **42** to the top of the 2" valve. Be sure to insert the seal before securing with a hose clamp.

Install the "T" fitting **43** to the top of the 6" pipe. Be sure to insert the seal before securing with a hose clamp.

### STEP 2

#### 3" FILL PORT ASSEMBLY

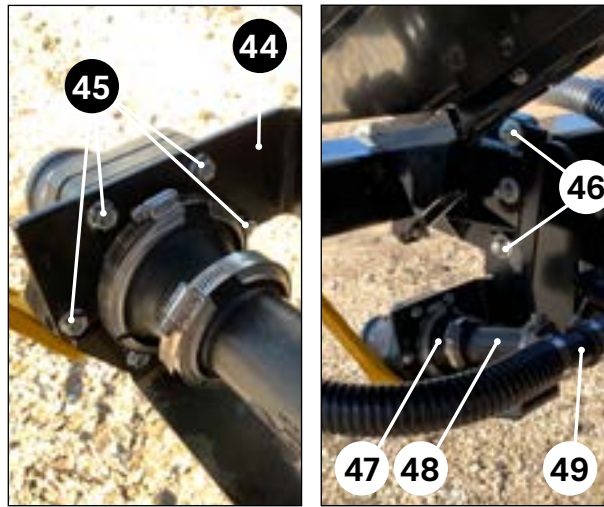

Remove (4) bolts on topside of 3" fill port valve (the side that the handle closes in the direction of). Retain bolts.

Install angled valve bracket **44** on backside of the valve with bolt going through bracket and then valve. Secure with previously removed bolts and provided flange nuts **45**.

Remove the top and bottom bolts from the back side of the left outrigger and attach the 3" fill port assembly in that same location **46**.

On the back side of the 3" fill port assembly, install the 3" to 2" reducer **47**, 6" standoff **48**, and "T" fitting **49**.

### STEP 3

#### HOSES - LEFT TO FILL PORT + FILL PORT TO CENTER

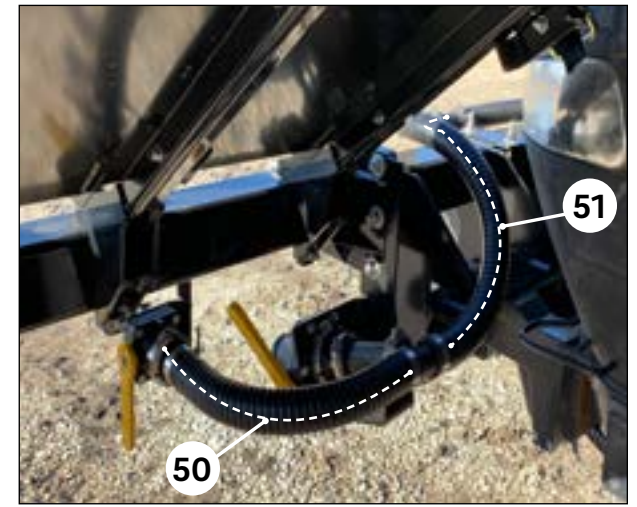

**NOTE: Use lubricant as needed to slide hoses onto hose barbs.**

On the left side of the tractor, route the hose from the 2" valve provided in the standard lines ground to the "T" just installed on the 3" fill port assembly **50**.

From the other side of the "T" on the 3" fill port assembly run a hose to the "T" on the 2" valve installed at the front center of the weight bracket mount **51**.



# OPTIONAL LINES KIT INSTALLATION

## CASE IH



### STEP 3 CONTINUED

#### HOSES - RIGHT TANK TO CENTER

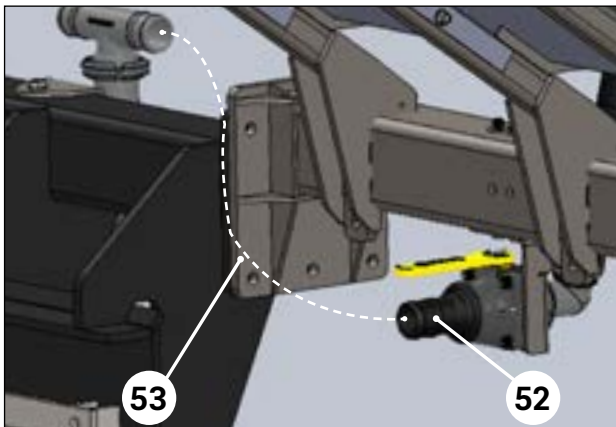

On the right side of the tractor, install the straight flange fitting **52** to the back of the 2" valve provided in the standard lines kit.

Run a hose from the straight flange fitting to the "T" on the 2" valve installed at the front center of the weight bracket mount **53**.

### STEP 3 CONTINUED

#### HOSES - CENTER TO REAR

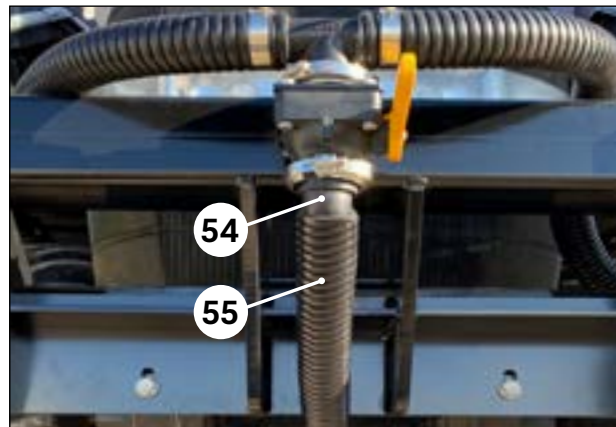

Install the remaining 45 degree fitting on the bottom side of the 2" valve at the front center of the weight bracket mount **54**.

Run the remaining hose **55** from that 45 degree fitting, under the tractor, all the way to the back where you can continue to plumb the rest of the system as you see fit. Be sure to zip tie this hose at multiple locations underneath the tractor.

### INSTALLATION COMPLETE

