



# 360 TANKS™

INSTALLATION INSTRUCTIONS  
JOHN DEERE 8RX MODELS



[360YIELDCENTER.COM](http://360YIELDCENTER.COM)

FOR QUESTIONS PLEASE CONTACT OUR  
PRODUCT SUPPORT TEAM AT 309-300-3120

2.26.21 • V2



# INSTALLATION INSTRUCTIONS

JOHN DEERE 8RX



## HELPFUL TOOLS

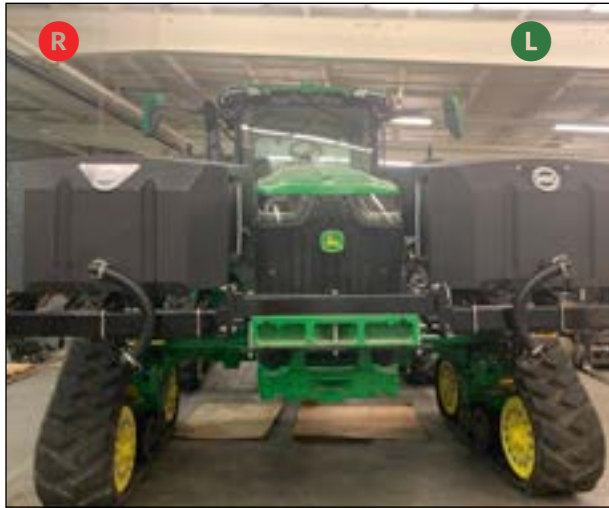

Impact

Socket Sizes: 30mm, 3/4", 5/16", 9/16" and 1-1/8"

15/16" Deep Well Socket

5/16" Driver

Wrench Sizes: 1-1/8", 15,16", 3/4" and 9/16"

Anti-seize

WD-40

Pipe Thread Sealant

White Thread Sealing Tape

**Remember right and left sides of the tractor are determined from the operator's seat.**

## BEFORE YOU BEGIN...

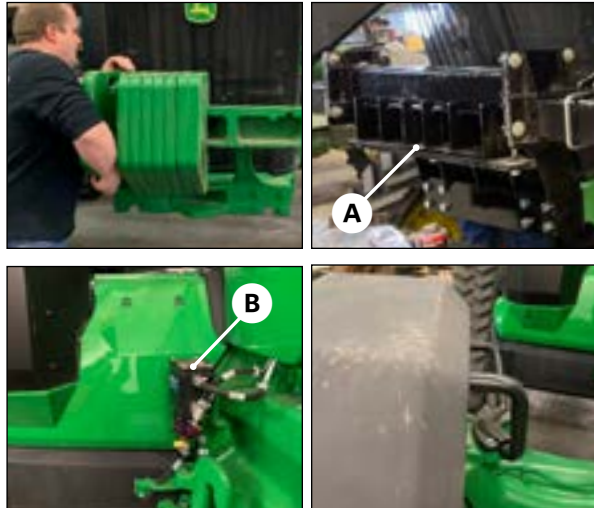

Remove weights. If your model has a short weight bracket it will need to be removed and replaced with a larger weight bracket and hardware provided by 360 Yield Center. **A**

**NOTE: Tractor weights will not be able to be reinstalled with the 360 TANKS system installed.**

Remove fenders, toolboxes, steps, and brackets attached to mounting location on tractor frame that would cause interference of the tank mounting structure.

**NOTE: If you have a water separator installed it will need to be removed at this time and can be re-installed later using the bracket provided by 360 Yield Center. **B****

Push front mirrors to the rear of the tractor.

## STEP 1

### FRONT MOUNT BRACKET

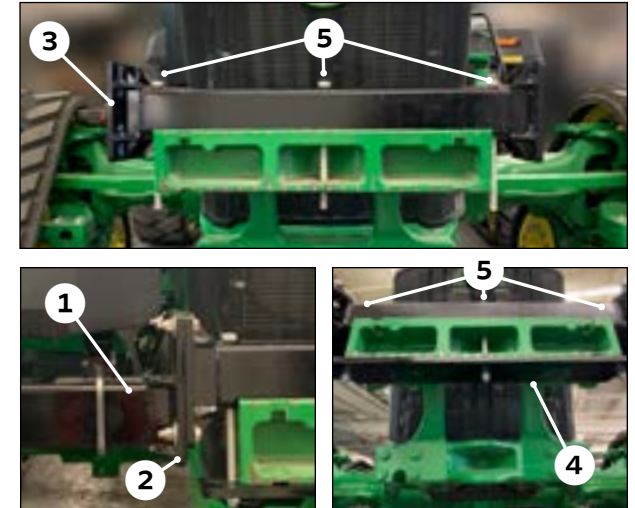

Set the front weight mount bracket **3** on top of the weight bracket with holes aligned with center hole of weight bar. Insert three bolts from the top to keep this bracket in place.

Using (12) 5/8" x 2-3/4" bolts, flat washers and nuts assemble each outrigger **1** onto the front weight mount bracket. Install a flat washer on each side of joint.

**NOTE: Outriggers should be oriented with the offset down **2**.**

**NOTE: If the optional lines kit is being installed, do not install the top or bottom bolts on the front, left side (from the cab).**

Using a 15/16" socket and wrench, tighten all bolts.

Install weight bracket plate **4** and secure with 3/4" x 13" bolts, washers, and lock nuts **5** using 1-1/8" socket and wrench. Leave nuts loose to allow for movement when installing tanks if needed.

# INSTALLATION INSTRUCTIONS

JOHN DEERE 8RX



## STEP 2

### REAR MOUNT BRACKETS

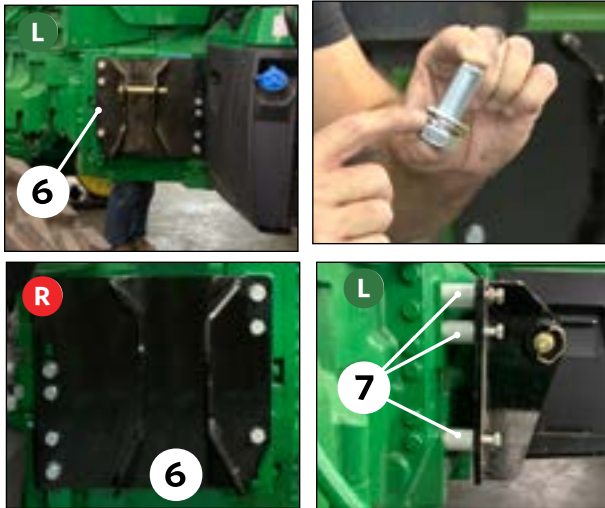

**NOTE:** Left and Right mount brackets are side specific. Ensure 1-1/4" axial pinhole is on top and all bracket holes align with holes on the tractor.

Remove caps, if in place, from threaded holes in the frame where rear mounting plate attaches. It is recommended to run a tap in the holes to clean out rust and/or paint and blow out any additional debris.

Install rear mount plate 6 to the tractor frame with (8) 20mm bolts, lock washers and flat washers. Use 30mm socket to slightly tighten bolts. Leave bolts loose to allow movement when installing tanks if needed. It is recommended to apply anti-seize to the bolts/holes.

**NOTE:** IVT / PowerShift E23 transmission will require spacers 7 installed behind front side of plate between mount bracket and tractor casting (if the seven bolts are on different planes).

Repeat on other side.

## STEP 3

### REAR MOUNTING STRUCTURE

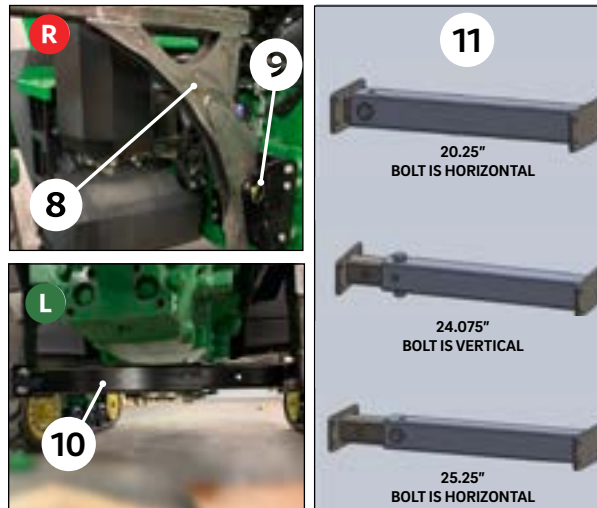

Using a forklift and strap, lift rear support 8 aligning hole in support with hole on the mount bracket.

Start 1-1/4" pin 9 from front of tractor and insert through mount plate and rear support. Secure with hairpin.

Repeat on other side.

Using (8) 5/8" x 2-3/4" bolts, lock washers, washers, and nuts install under tractor support 10 by lifting one rear mounting structure at a time. Leave nuts loose.

**NOTE:** 11 The under tractor support is adjustable to accommodate the wide variation of tractor sizes. Determine the length of the under tractor support needed for your tractor and adjust and secure the under tractor support at the corresponding setting. When the under tractor support is installed between the two rear supports, the top of the rear supports should be parallel to the ground.

## STEP 4

### SIDE SIGHT GAUGE

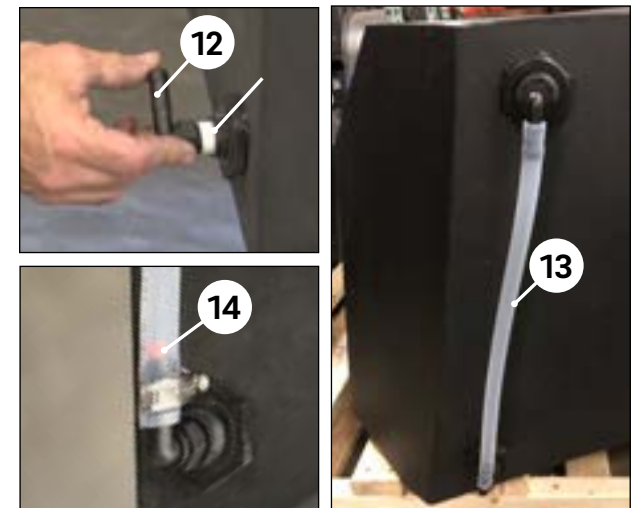

Apply white thread sealing tape to threads on each of the elbow hose fittings 12.

Screw elbows into side of tank and orient towards each other.

Install clear tube 13 between elbows, securing each end of the hose to the elbow with worm gear hose clamp. **Ensure to insert red float ball 14 inside tube before securing both ends.**

Repeat for sight gauge on second tank. When tanks are installed, side sight gauges will be between tank and tractor.

**NOTE:** Use lubricant as needed to slide hose onto fittings.

# INSTALLATION INSTRUCTIONS

JOHN DEERE 8RX



## STEP 5

### REAR SIGHT GUAGE

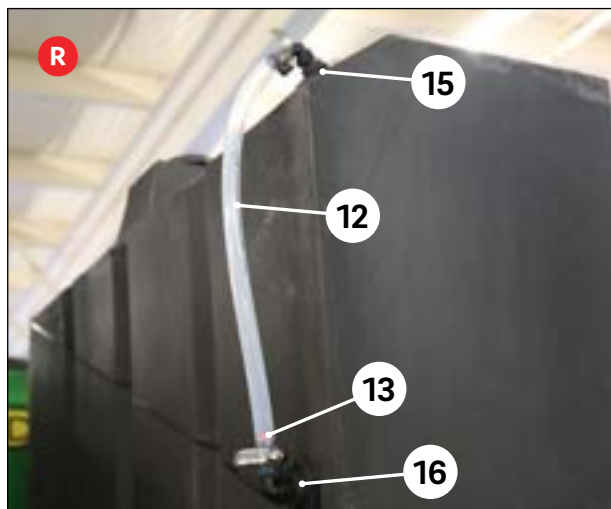

Apply white thread sealing tape to threads on each of the elbow hose fittings.

Screw elbows into top **15** and bottom **16** screw holes in back of tank. Ensure hose barb connectors are positioned towards each other.

Install clear tube **12** between elbows, securing each end of the hose to the elbow with worm gear hose clamp. **Ensure to insert red float ball **13** inside tube before securing both ends.**

Repeat for rear sight gauge on second tank.

## STEP 6

### TANKS

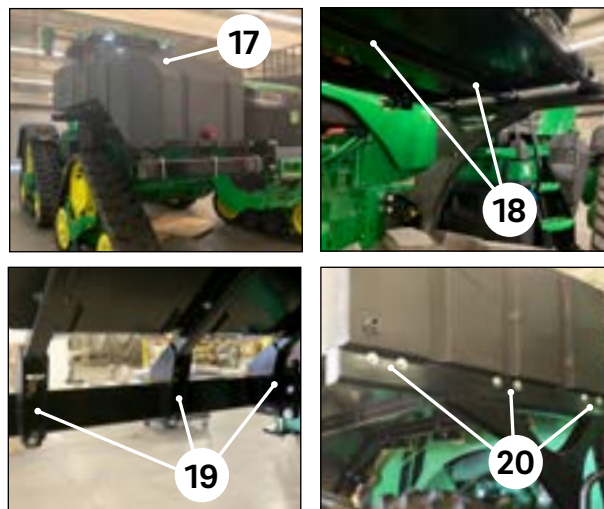

Using a forklift and fork extensions, lift the first tank **17** off the shipping pallet. Ensure forks do not stick out past the tank so that they will not come in contact with the tractor.

Place tank on front and rear supports ensuring holes on the tank support are aligned with holes on the rear support.

**NOTE: If rear support bolts do not line up, loosen the bolts that hold together the pans and support tubes under the tank **18** to allow additional movement. Do not remove bolts completely.**

**NOTE: Situate front of the tanks first before aligning back.**

The front will sit on the front mount bracket. Loosely secure (3) front u-bolts using clipped washers and 5/8" nylock nuts **19**.

Secure the rear of the tank to the rear support by loosely installing 1/2" bolts, washers (one on each side), and nuts through backside **20**. Do not tighten. Repeat for second tank.

## STEP 7

### TIGHTEN HARDWARE



Once both tanks have been properly aligned and loosely secured, tighten **all** bolts previously left loose on both sides:

- Front Mount Bracket
- Under Tractor Support
- Rear Mount Brackets
- Tank Assembly Front U-bolts
- Tanks Assembly Rear Bolts
- Tank Assembly Pan and Support Bolts (if loosened to help with tank alignment)

If applicable, reinstall the water separator using the bracket and hardware provided in the kit from 360 Yield Center.

# INSTALLATION INSTRUCTIONS

JOHN DEERE 8RX



## STEP 8 VENT ASSEMBLY

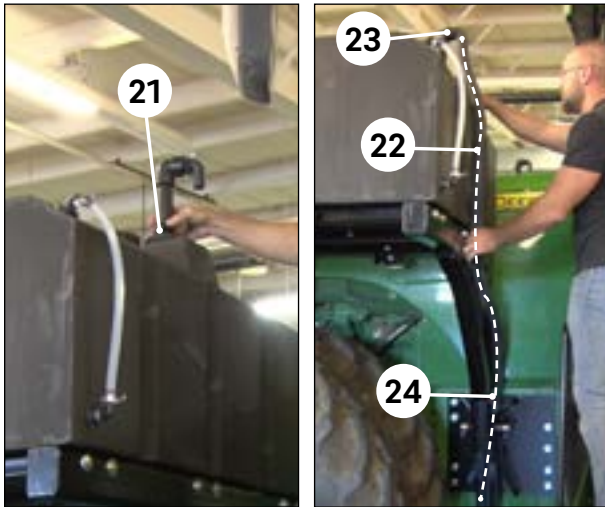

Install bottom 1-1/4" fitting into bulkhead towards the rear of the tank **21**. Screw down to tighten and ensure port is faced to the rear.

Route the 1-1/4" EPDM rubber hose **22** starting from the hose barb **23** of the vent down along the support tube and through the slot between the support tube and rear mount bracket **24**.

Use zip ties to secure vent hose at multiple locations along the rear support.

Trim the hose as you see fit.

Repeat for vent assembly on the second tank.

## STEP 9 INSTALL STANDARD LINES KIT



**NOTE: Hose assemblies are left and right specific.**

Remove threaded flange fitting **25** from the elbow included in the hose assembly using 5/16" socket - ensuring to keep the seal and hose clamp.

Generously apply thread sealant on the threads of the flange **25** and thread into the front of the tank. Install 90 degree elbow to flange.

Install hose assembly mounting plate **26** to front mount bar with (2) 1/2"x6" bolts, flat washers and nuts **27**. Tighten with a 3/4" socket and wrench.

Measure and cut hose to proper length up to the 90 degree elbow. Once hose is correct length for your setup, secure to flange with hose clamp.

Repeat on the second tank.

## INSTALLATION COMPLETE



**NOTE: If the optional lines kit is being installed, please continue with the "Optional Lines Kit" installation instructions starting on page 5.**

# OPTIONAL LINES KIT INSTALLATION

## JOHN DEERE



### STEP 1 3" FILL VALVE

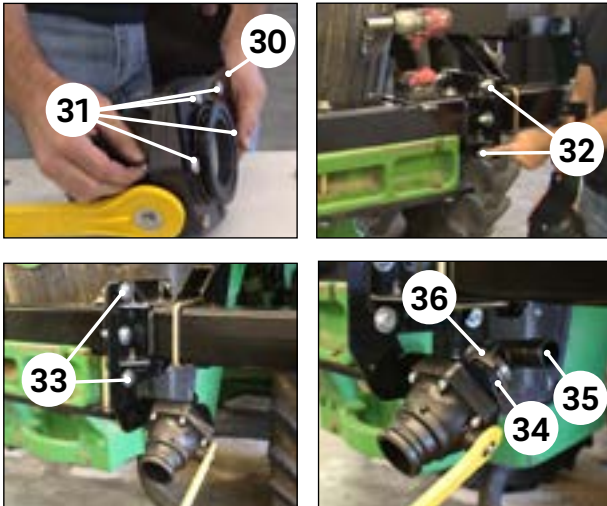

The following optional lines kit installation is shown on a John Deere R Series. Installation on an 8RX model may vary slightly.

**NOTE: Ensure there is a seal between every flange connection.**

Remove (4) bolts on topside of 3" ball valve (the side that the handle closes in the direction of). Retain bolts.

Install angled valve bracket **30** on backside of the valve with bolt going through bracket and then valve. Secure with previously removed bolts and provided flange nuts **31**.

Using 15/16" socket and wrench remove front top and bottom bolts from left outrigger weight mount bracket **32** (if not previously left uninstalled). Install fill valve bracket on outside and secure with bolts **33**.

Install 3" to 2" flange reducer **34** and 2" barbed tee fitting **35** on back of 3" valve. Install seal and secure with hose clamp **36**.

### STEP 2 2" CENTER FILL VALVE & TEE

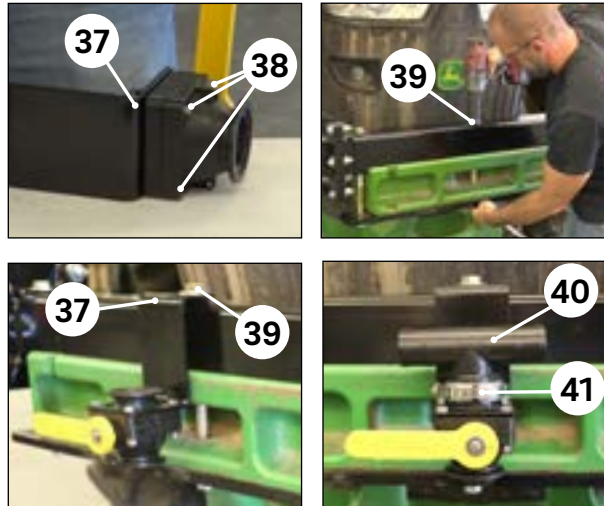

Remove the (4) bolts from the 2" valve. Retain bolts.

Install 90 degree valve bracket **37** on the backside of valve. Secure with previously removed bolts and provided flange nuts **38**.

Using 1-1/8" socket and wrench remove center bolt from front mount bracket beam **39**. Install valve bracket **37** on top of front mount bracket beam and secure by reinstalling 13" bolt through the bracket and bar **39**.

Install tee fitting on top of the 2" valve **40**. Insert the seal and secure with a hose clamp **41**.

### STEP 3 PLUMB LEFT TANK

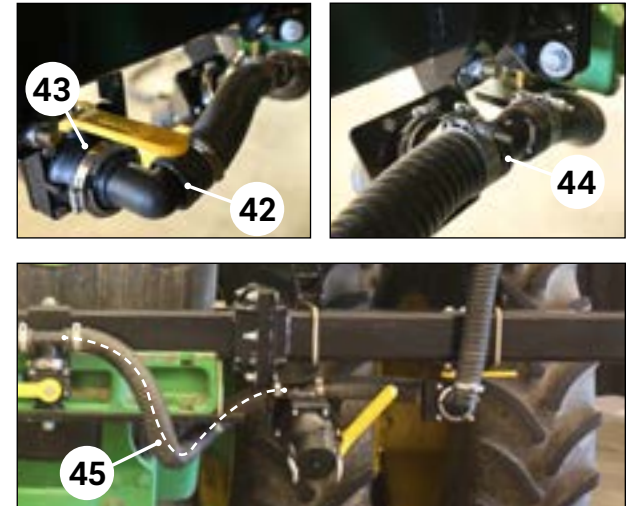

**NOTE: Use lubricant as needed to slide hoses onto hose barbs.**

Install 14" hose and flange **42** on back of the left side 2" fill valve **43**. Insert seal and secure with hose clamp.

Slide the open end of the hose onto the tee barb on the back of the 3" valve **44**. Secure with hose clamp.

Route 39" hose **45** from 3" fill valve to tee barb on 2" center fill valve. Secure hose on both ends with hose clamps.

# OPTIONAL LINES KIT INSTALLATION

## JOHN DEERE



### STEP 4 PLUMB RIGHT TANK

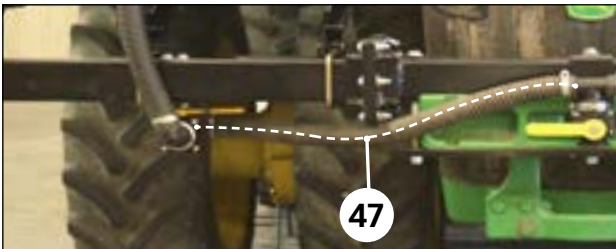

Install elbow **46** on back of right side 2" fill valve with seal and hose clamp. Ensure hose barb is directed toward the center of the tractor.

Route hose between elbow hose barb and front tee barb on the 2" valve **47**. Secure hose at both ends with hose clamps.

### STEP 5 PLUMB TO REAR



Install 2" flange/barb fitting onto end of 40' hose. Secure with hose clamp.

Insert seal and secure 40' hose to 2" center fill valve using a hose clamp **48**.

Route hose to the rear of the tractor. Utilizing provided zip ties, secure the hose to the belly of the tractor.

### INSTALLATION COMPLETE

